

A2FO Series Axial Piston Fixed Displacement Pump

Product show and brief introduction

Open circuits

Sereis 6
Sizes 10...180
Nominal pressure 40MPa
Peak pressure 45MPa



Features

- Fixed displacement pump A2FO of axial piston, bent axis design, suitable for hydrostatic drives in open circuits
- Use in mobile and industrial applications
- Output flow is proportional to drive speed and displacement
- The drive shaft bearings are designed to give the service life expected in these areas of operation
- High power density
- High overall efficiency
- One piece pistons with piston rings

Installation and Commissioning Notes

● General

The pump case must be completely filled up with hydraulic fluid during startup and during operation (filling the case chamber). The pump must be started up at low speed and no load until the system has been bled completely.

If stopped for an extended period, fluid may drain out of the case through the service lines. When restarting, make sure that the case contains sufficient fluid.

The leakage fluid inside the case chamber must be drained off to the tank through the highest case drain port. The min. suction pressure at port S must not fall below 0.08 MPa absolute.

● Installation position

Optional

● Installation below the tank

Pump below min. fluid level in the tank (standard)

- Fill axial piston pump before startup via the highest case drain port
- Additional measures required for installation position 2 (shaft facing up); with installation position 2, make sure that the pump case is completely full before starting up. Bleed at port R. An air pocket in the bearing area is leading to damage of the axial piston pump.
- Recommendation: Fill up suction lines.
- Run the pump at low speed until the system is bled completely.
- Minimum immersion depth of leakage line in tank: 200mm (relative to the min. fluid level in the tank).

● Installation above the tank

Pump above minimum fluid level in tank

- Proceed in same way as below the tank installation.
- Additional measures for installation position 1 and 2. If stopped for an extended period, fluid may drain out of the case chamber through the service lines (air enters through the shaft seal). The bearing will therefore not be properly lubricated when the pump is started up again. Fill the axial piston pump before restarting via the highest case drain port. Installation position 2: bleed at port R.
- Additional measures required for installation position 2 (shaft facing up): In this installation position the bearings will not be properly lubricated, even if there is still some fluid in the case chamber. Putting a non-return valve (opening pressure 0.05 MPa) in the leakage line can prevent the system emptying through the line.
- Note: min. admissible pressure at port S.

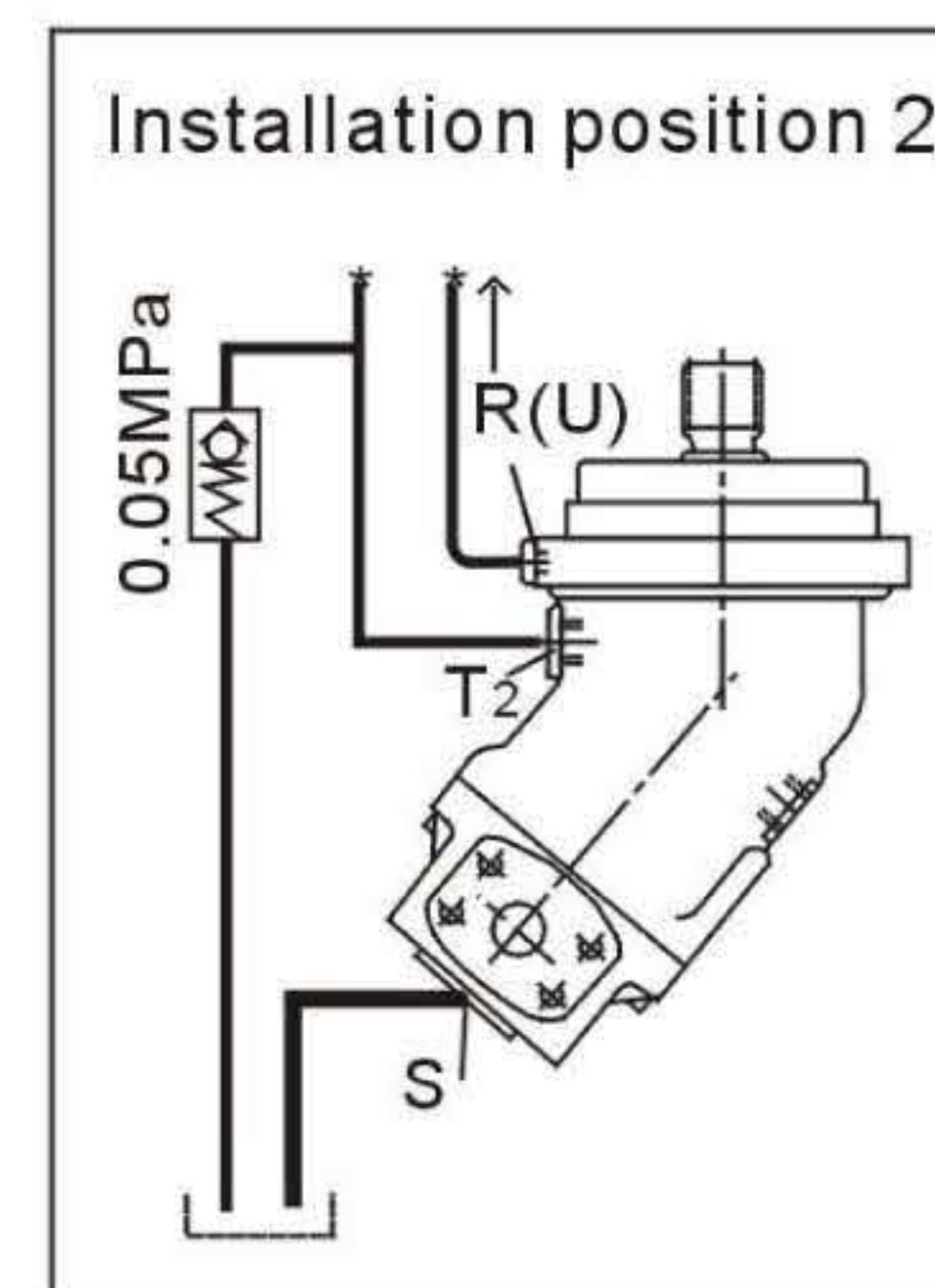
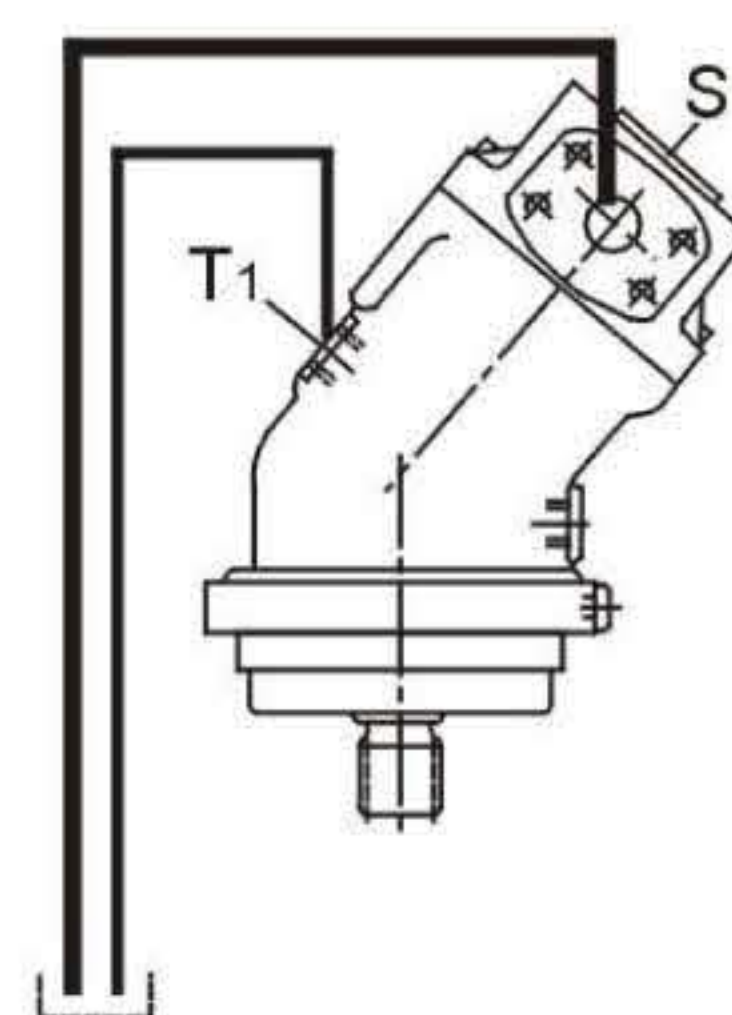
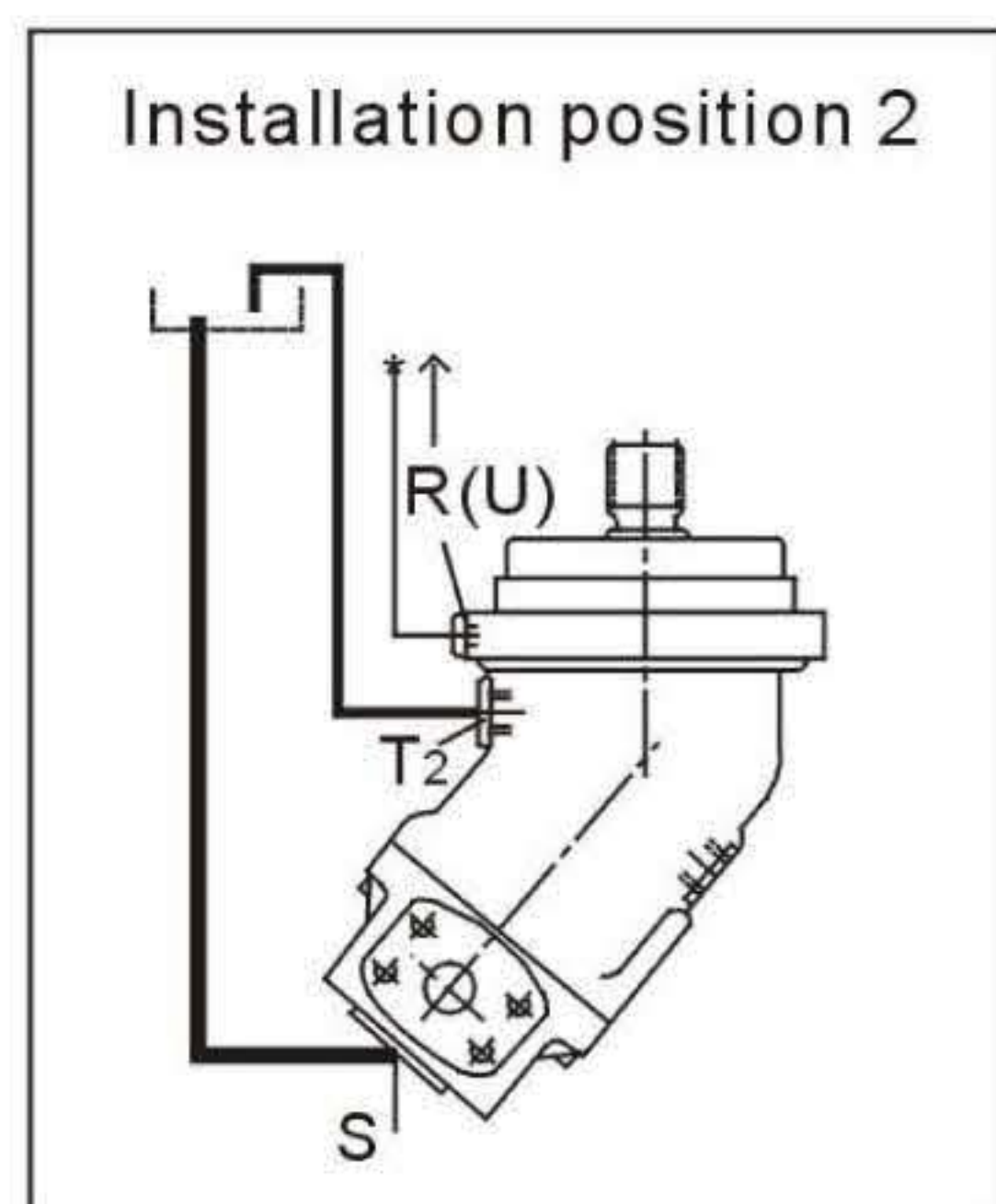
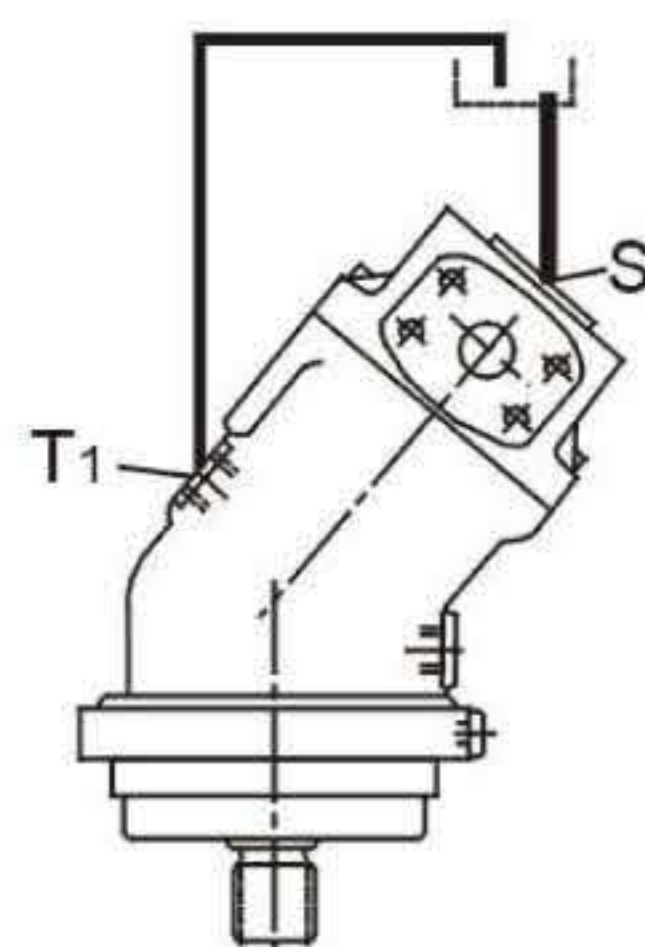
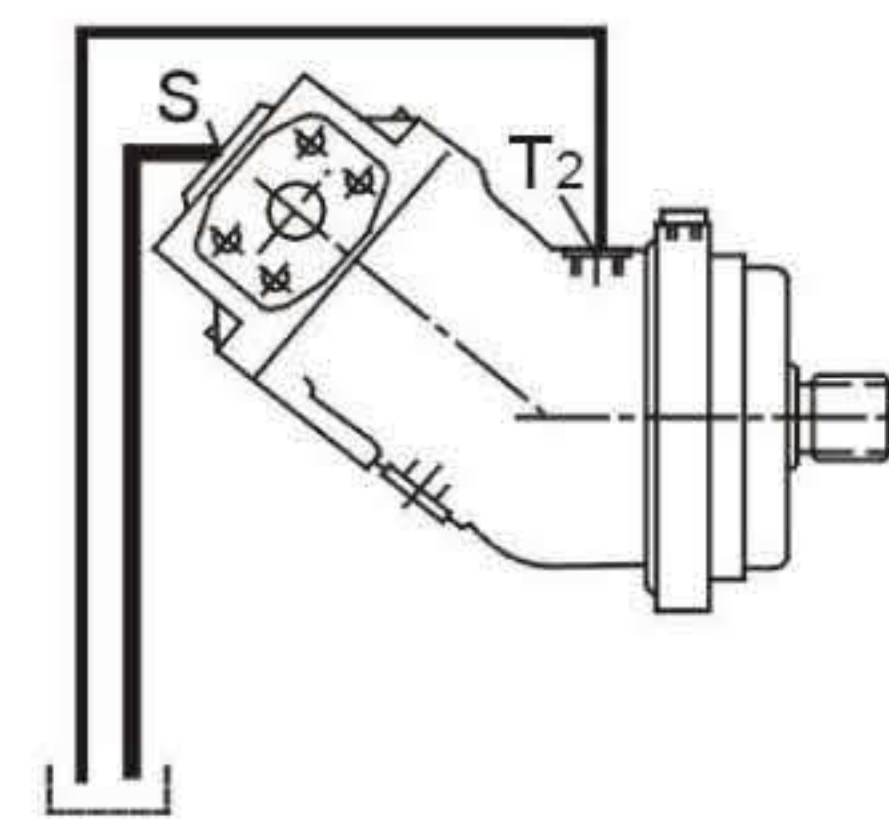
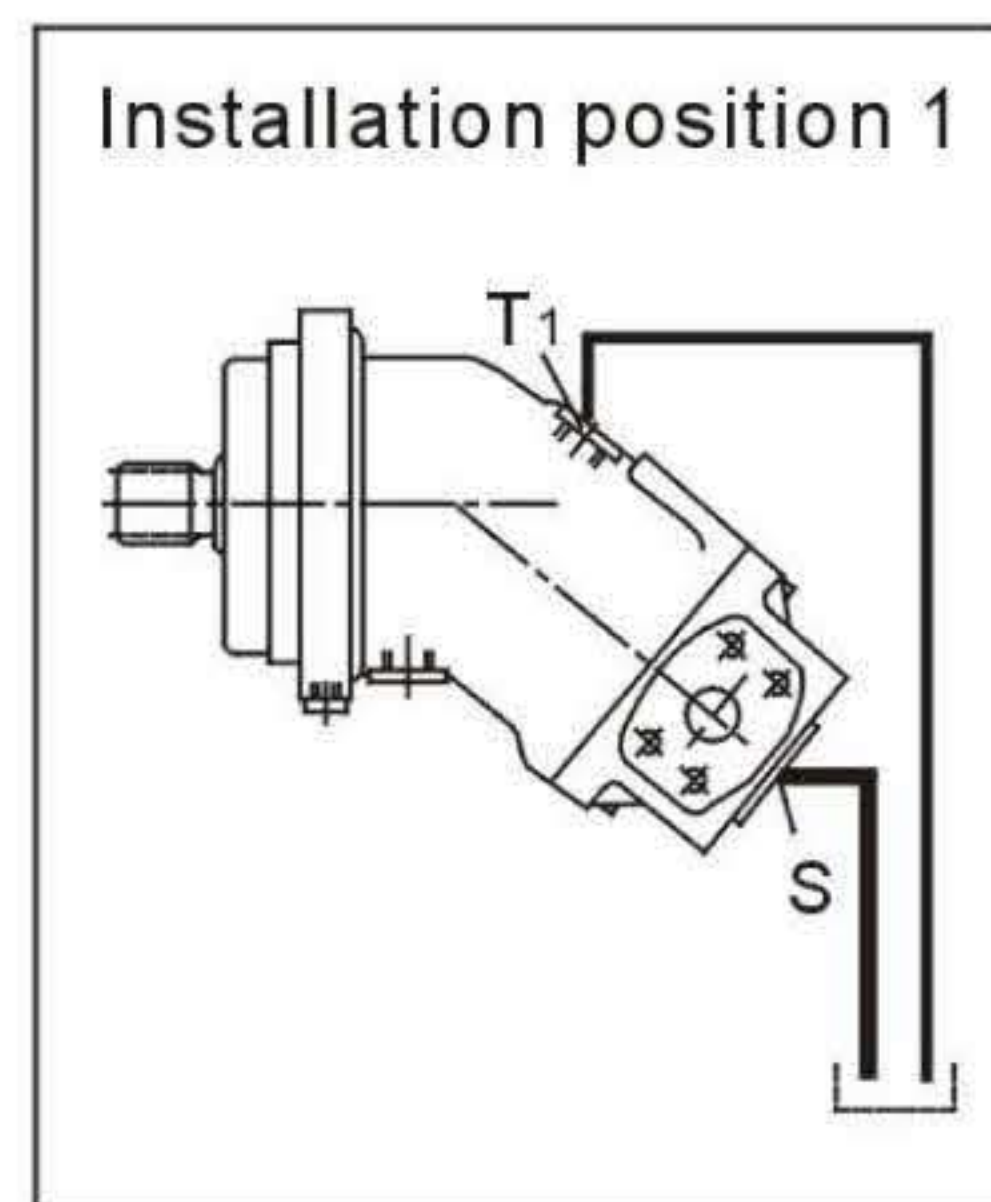
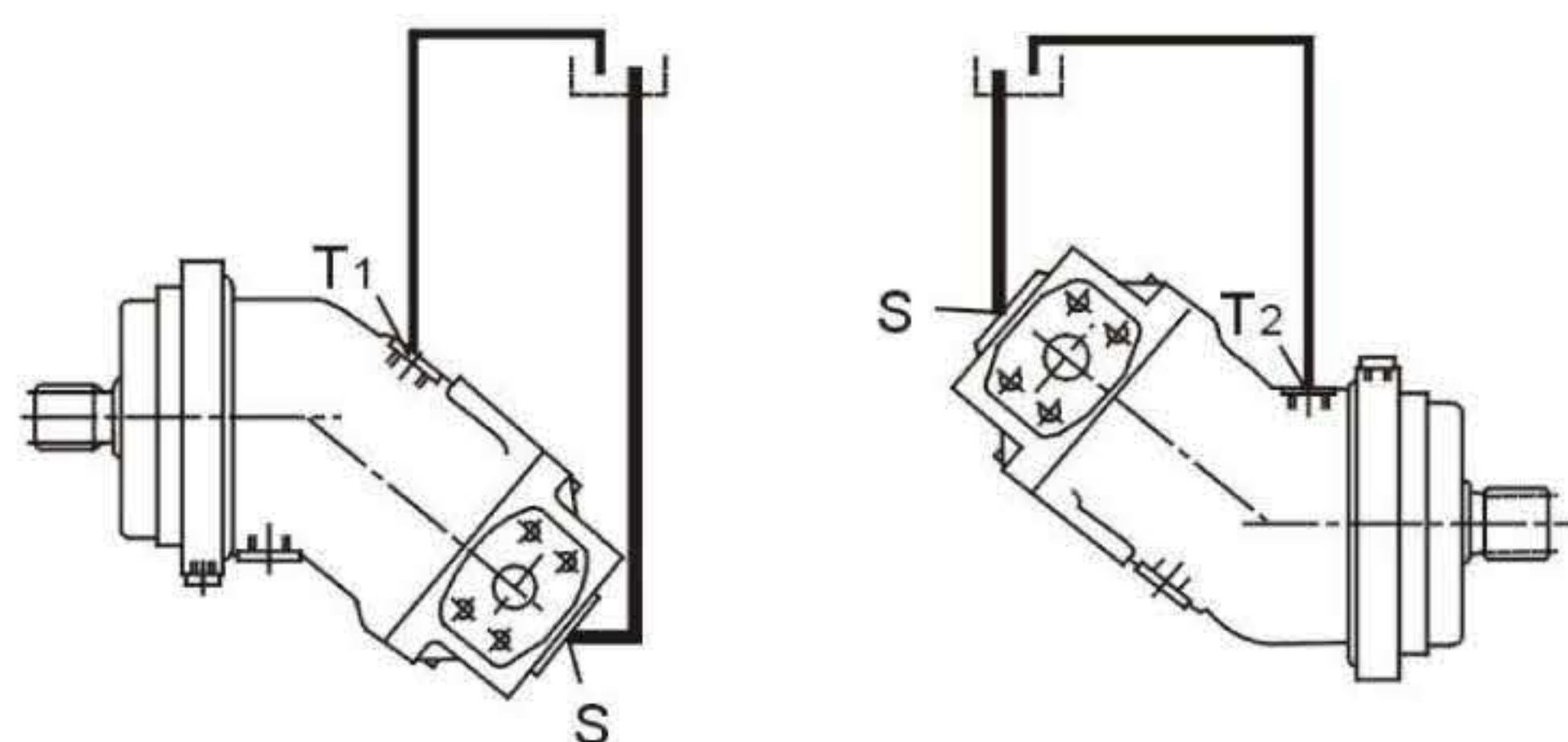

Installation dimensions

A2F0160/61R-※B05
A2F0180/61R-※B05

Counter-clockwise rotation:
port plate is rotated through 180°

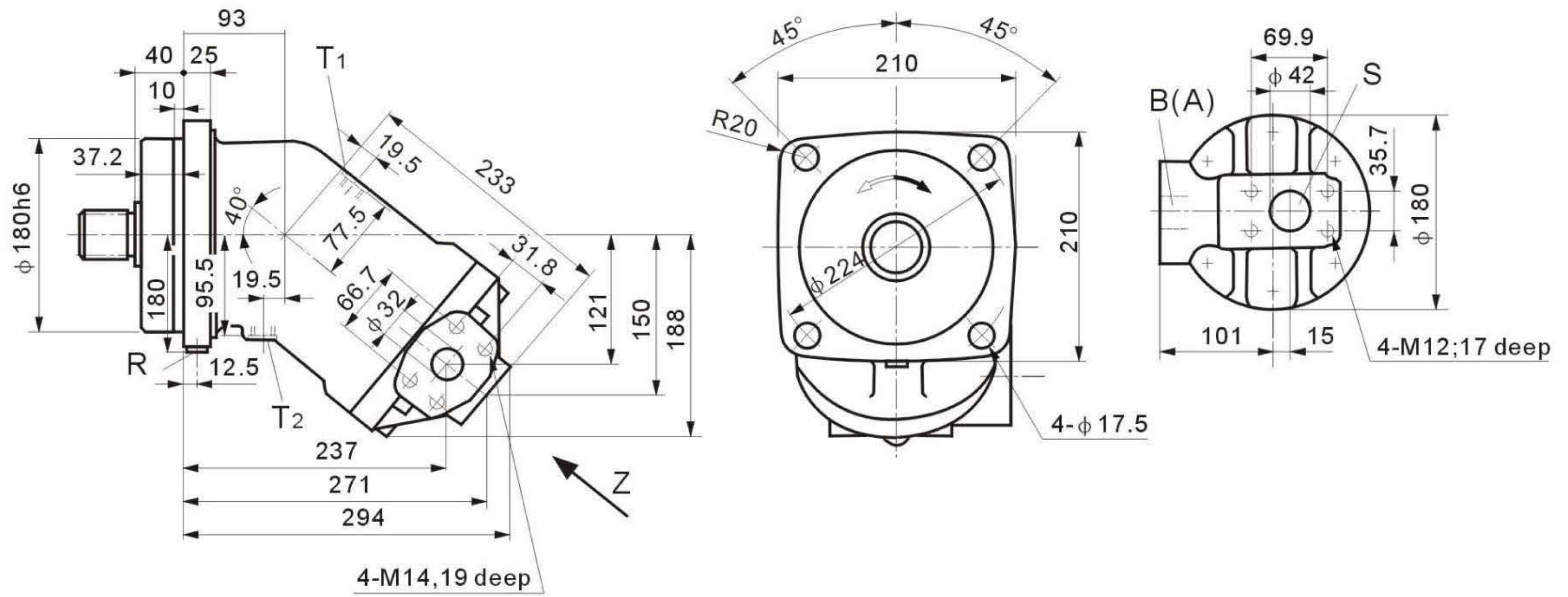

Ports

B(A)	Service line port (high pressure series)	SAE 1 1/4"
S	Suction port (standard pressure series)	SAE 1 1/2"
T ₁ , T ₂	Case drain ports (T ₁ plugged)	M22×1.5
R	Air bleed (plugged)	M14×1.5

Shaft ends

Sizes 160,180
A Splined shaft DIN 5480
W50×2×30×24×9g
PN = 40 MPa

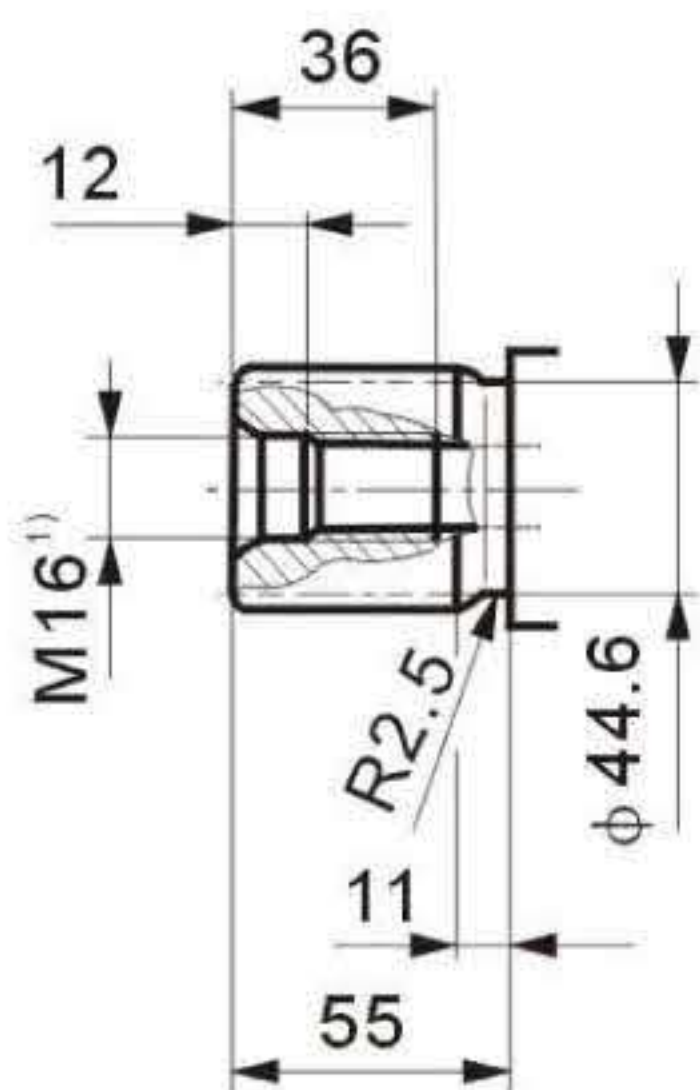

Size 160
A Splined shaft DIN 5480
W45×2×30×21×9g
PN = 40 MPa

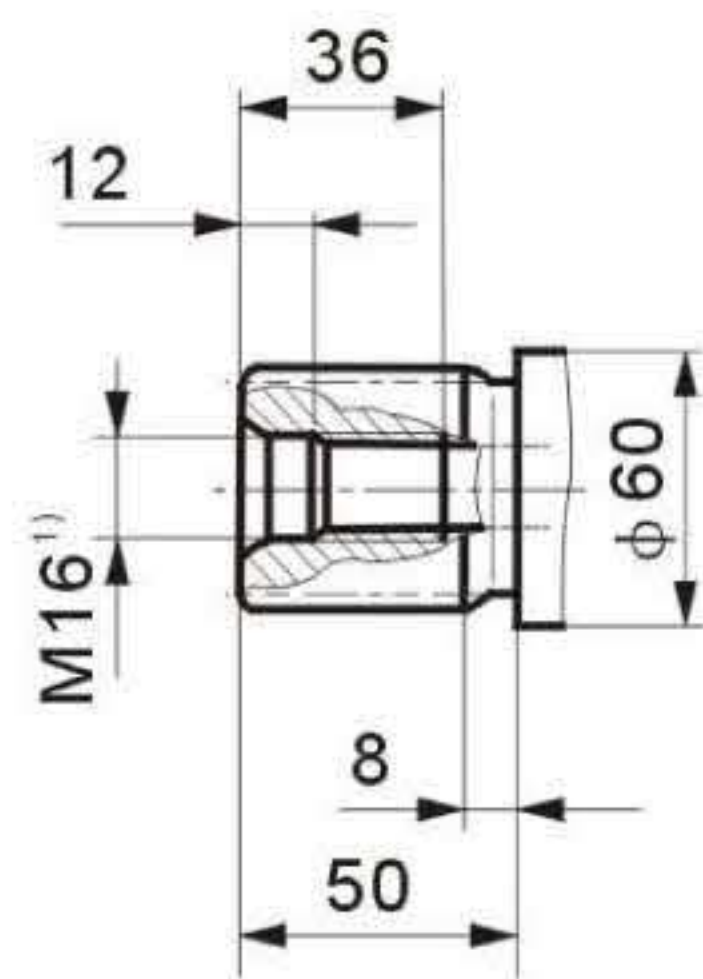

Sizes 160,180
P Parallel keyed shaft
DIN 6885, As14×9×70
PN = 35 MPa

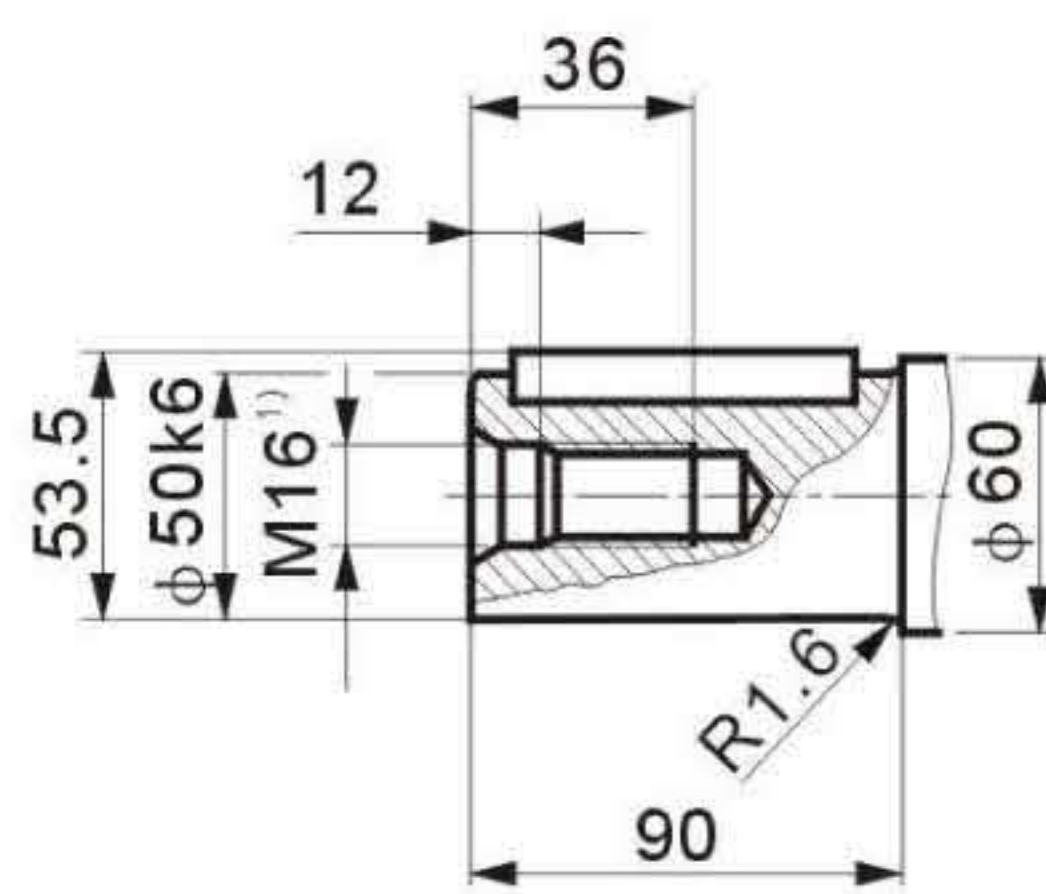

Size 160
P Parallel keyed shaft
DIN 6885, AS14×9×70
PN = 35 MPa

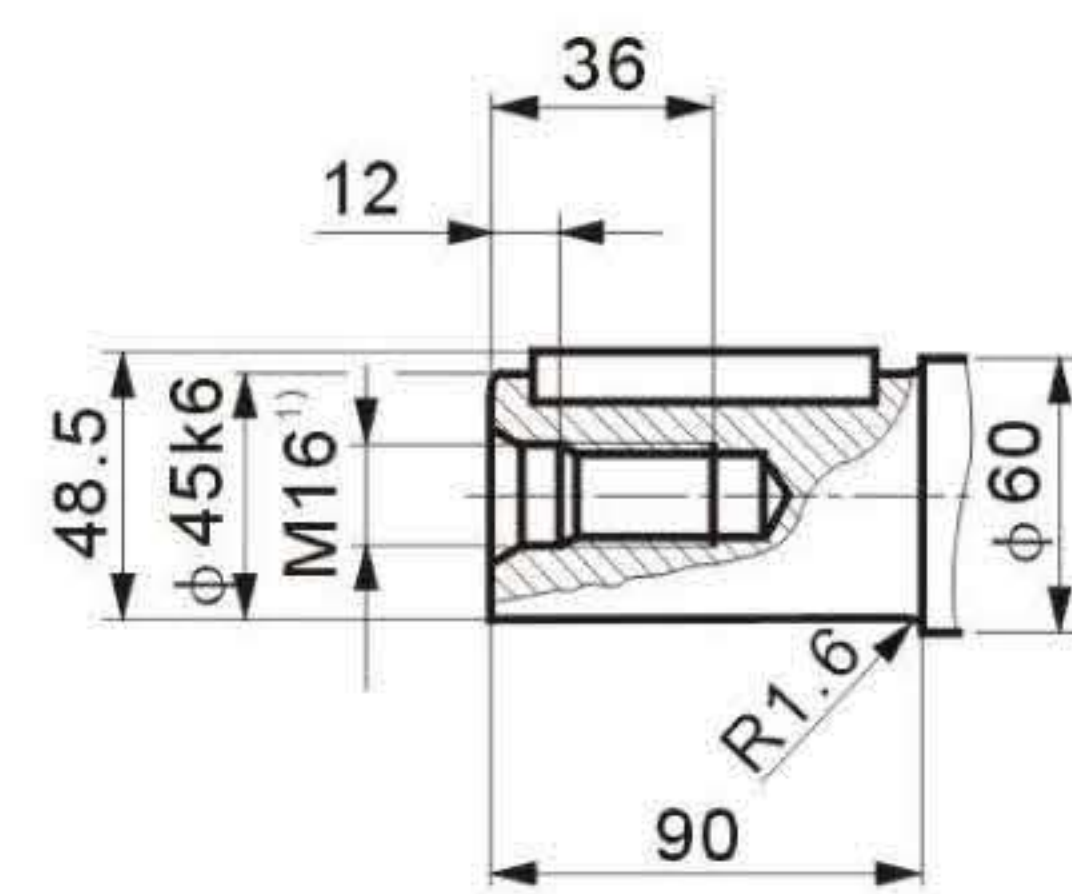

1) centering bore according to DIN 332 (thread according to DIN 13)

Installation dimensions

A2F0107/61R-※B05
A2F0125/61R-※B05

Counter-clockwise rotation:
port plate is rotated through 180°

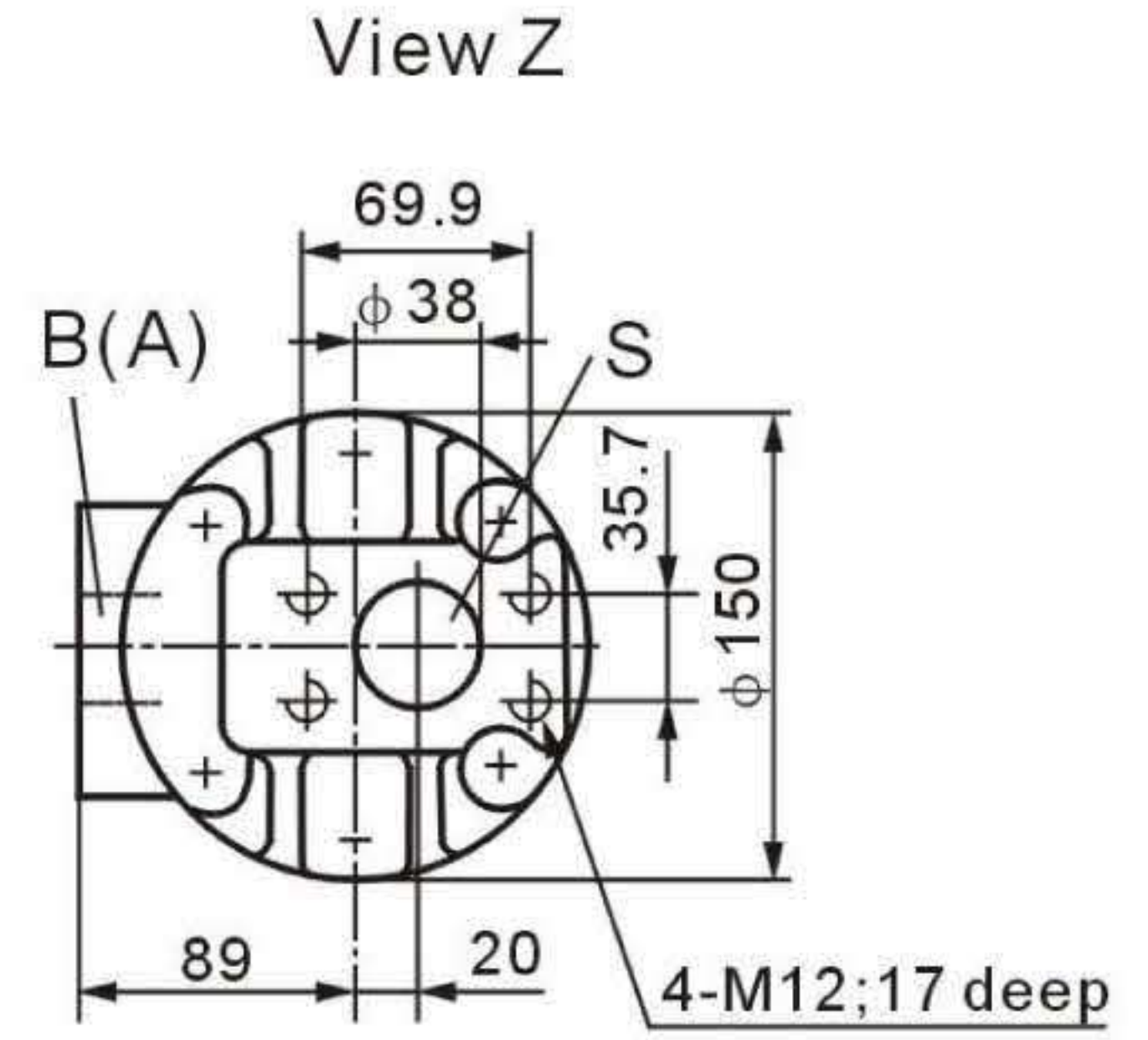
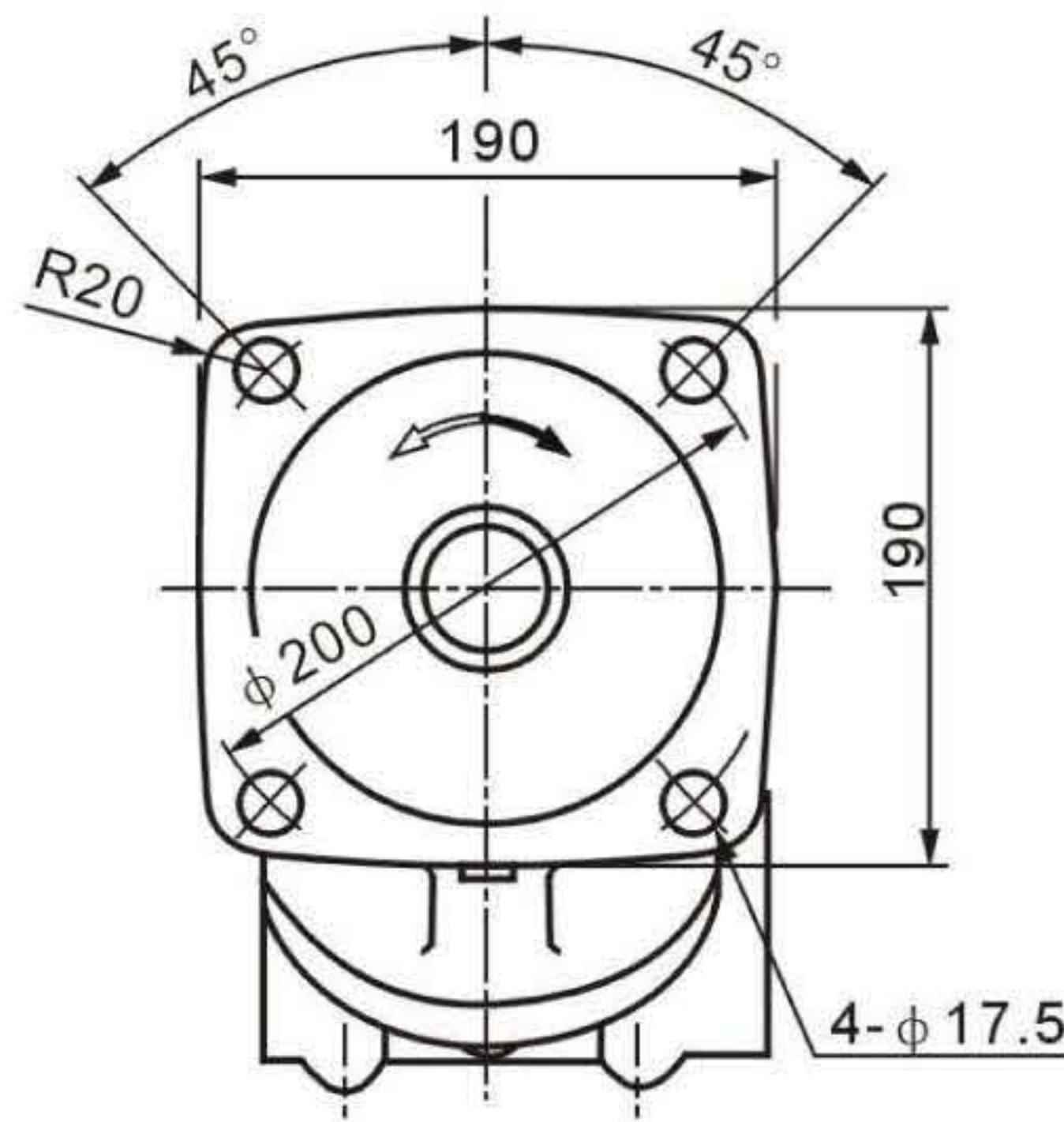
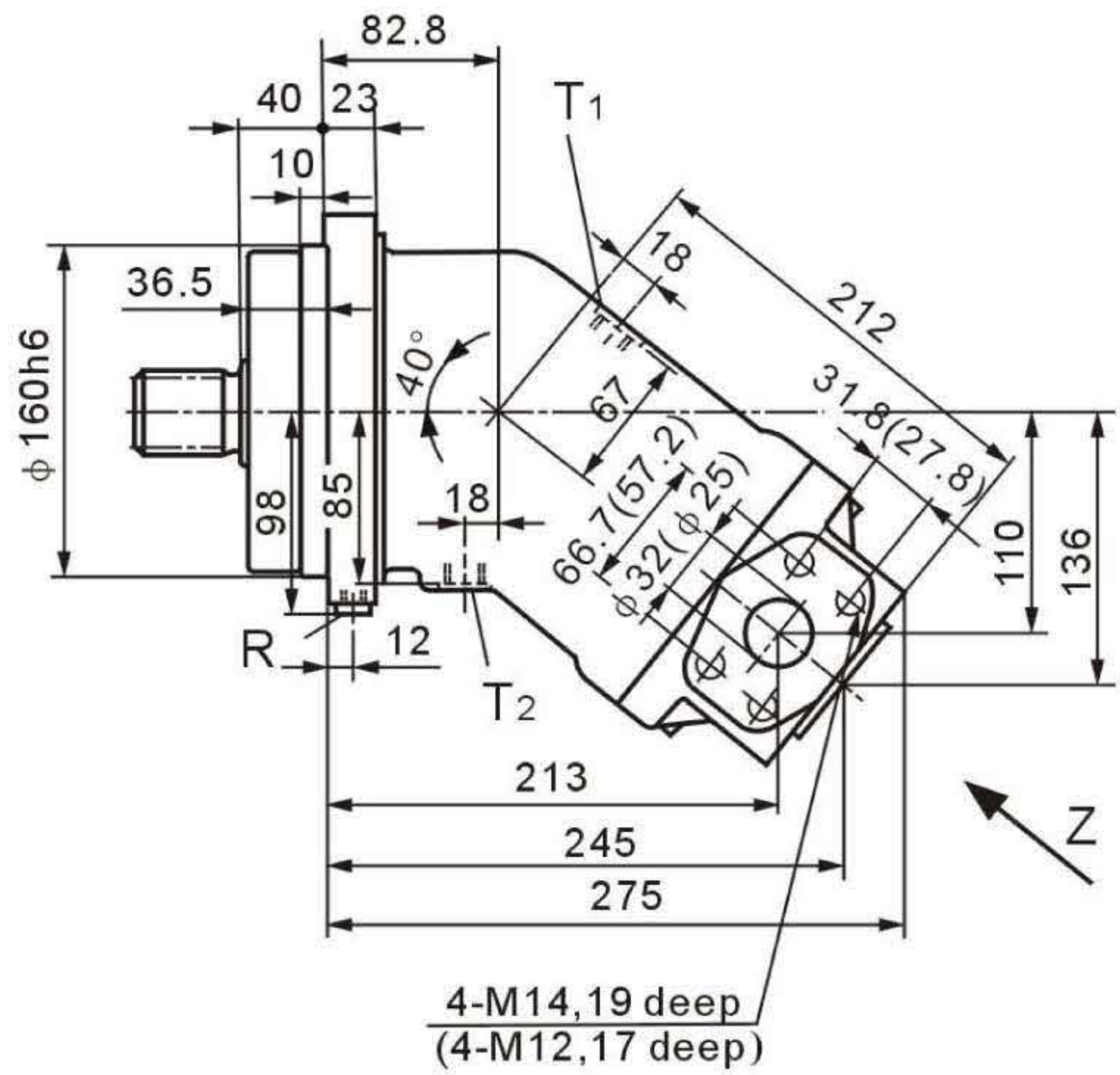

(dimensions for size 107 in bracket)

Ports

B(A)	Service line ports (high pressure series)	SAE 11/4" (1")
S	Suction port (standard pressure series)	SAE 1 1/2"
T ₁ , T ₂	Case drain ports (T ₁ plugged)	M18×1.5
R	Air bleed (plugged)	M14×1.5

Shaft ends

Sizes 107,125
A Splined shaft DIN 5480
W45×2×30×21×9g
PN = 40 MPa

Size 107
Z Splined shaft DIN 5480
W40×2×30×18×9g
PN = 40 MPa

Sizes 107,125
B Parallel keyed shaft,
DIN 6885, AS14×9×63
PN = 35 MPa

Size 107
P Parallel keyed shaft
DIN 6885, AS12×8×63
PN = 35 MPa

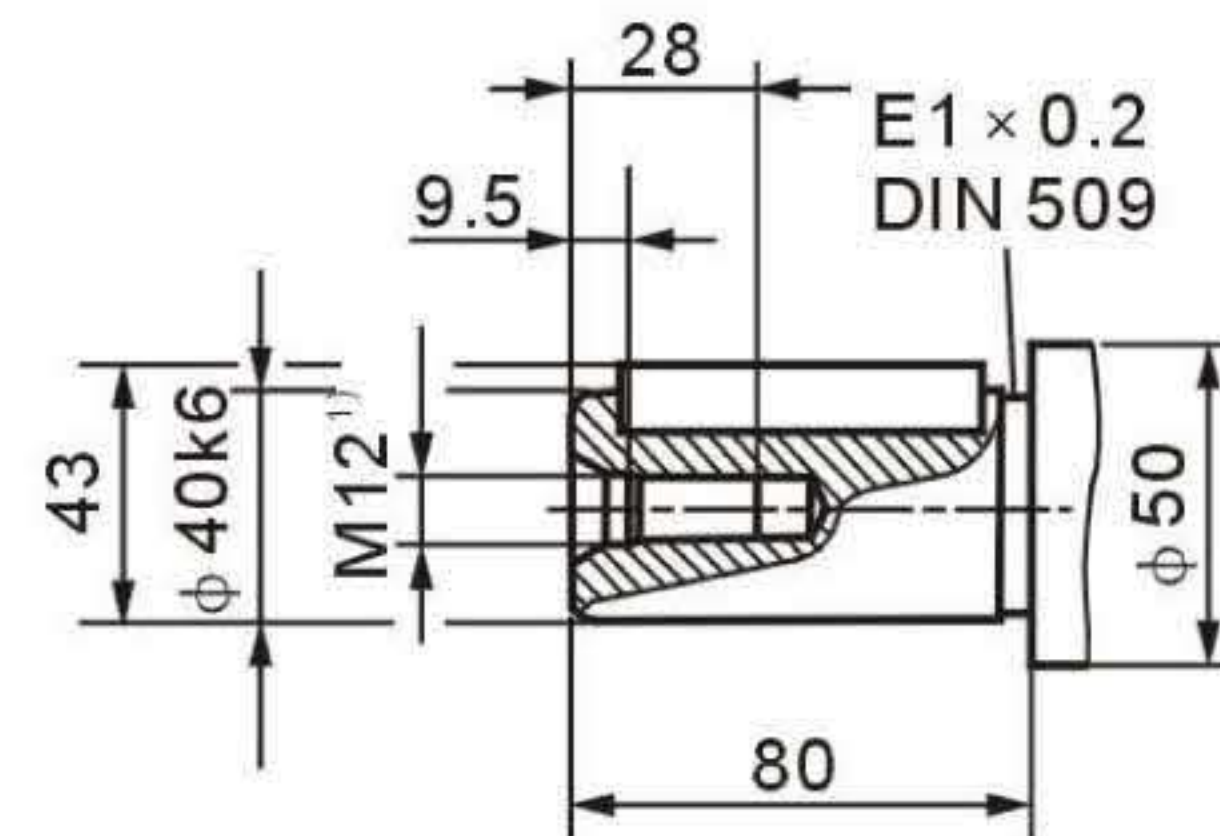
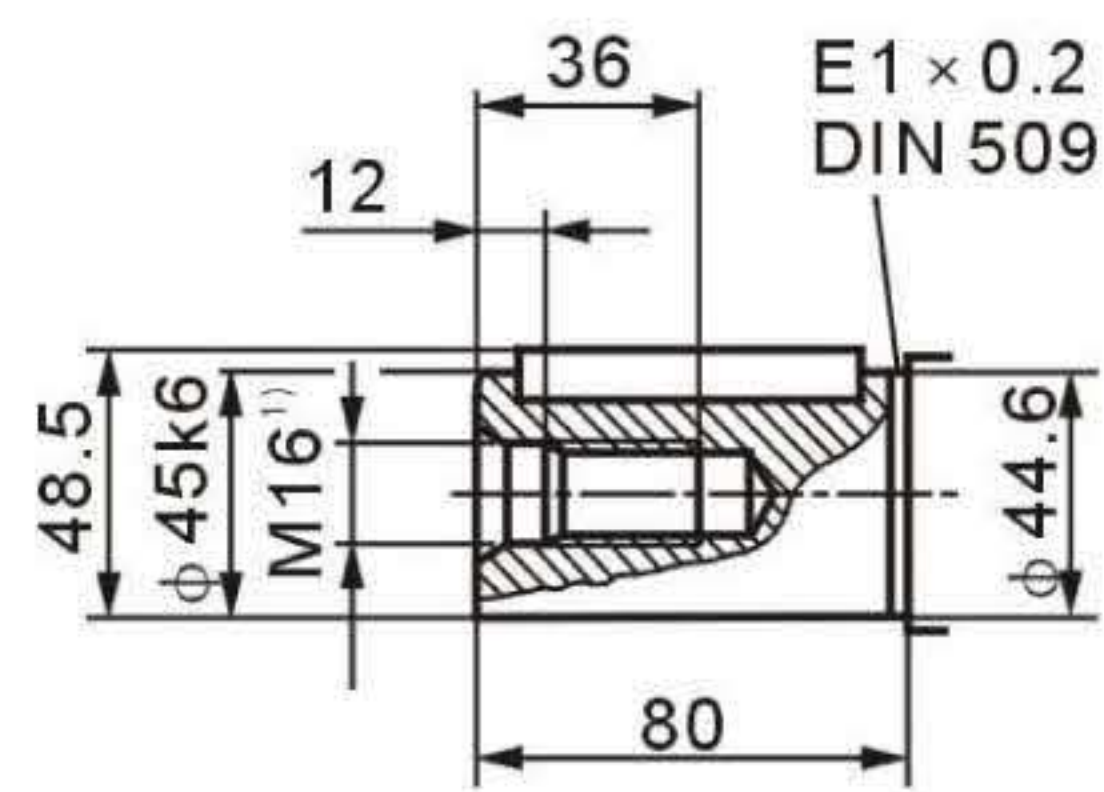
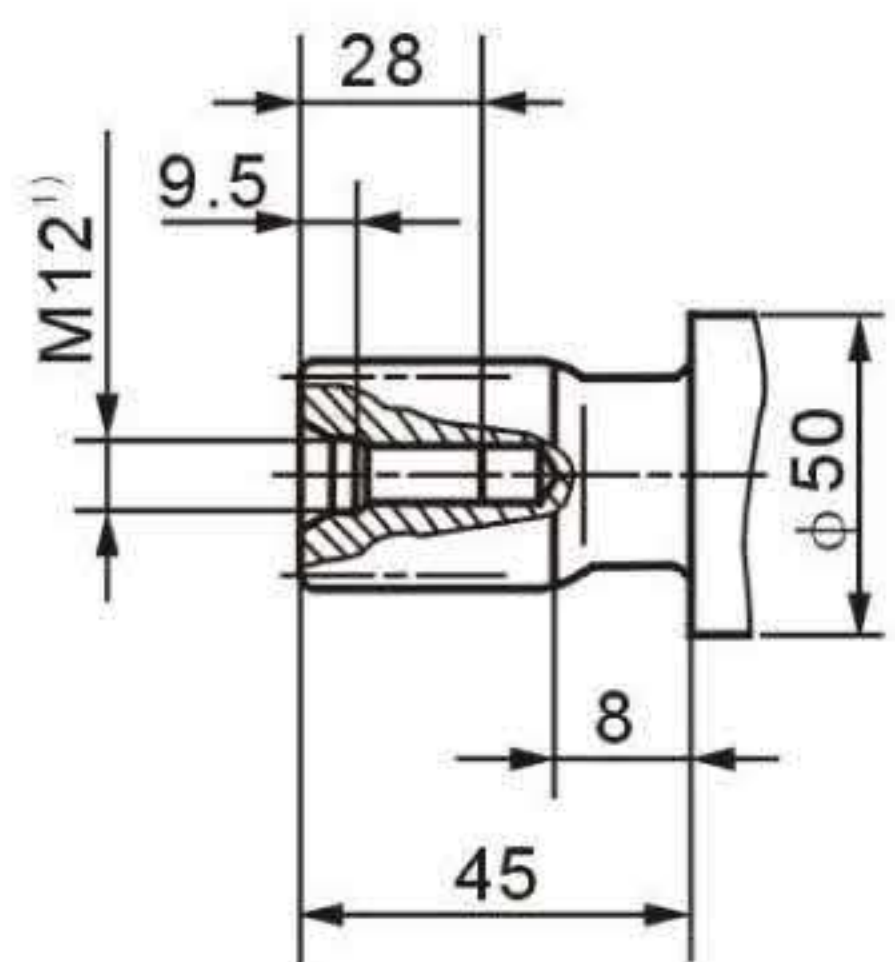
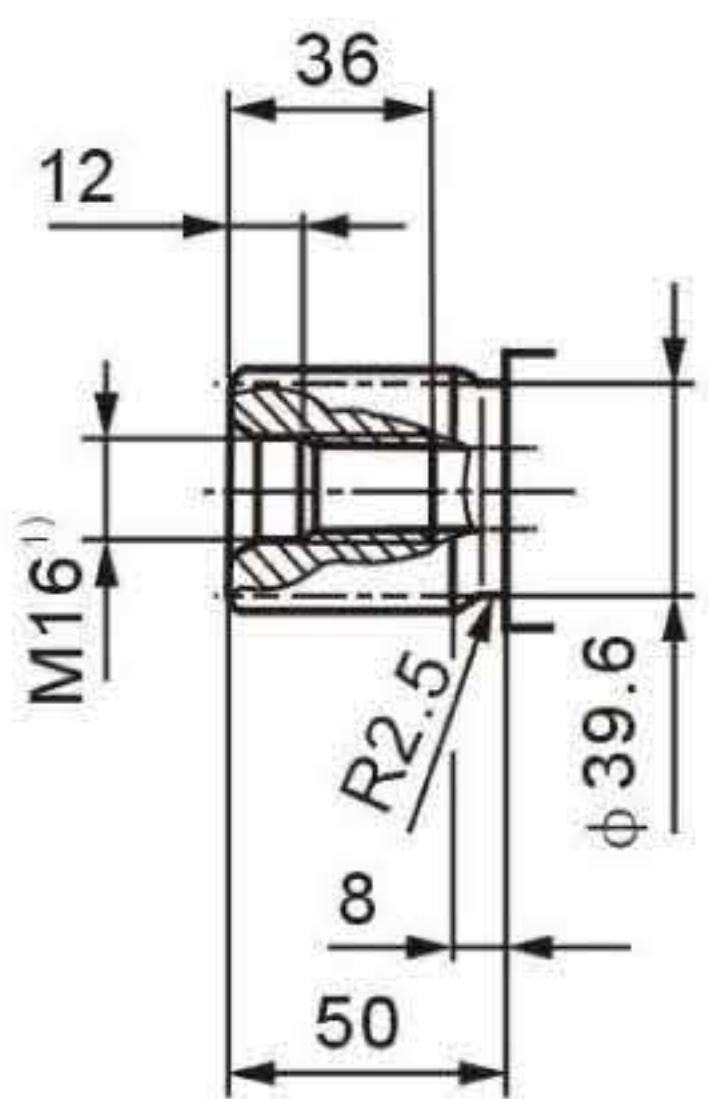

1) centering bore according to DIN 332 (thread according to DIN 13)

Installation dimensions

A2F080/61R-※B05
A2F090/61R-※B05

Counter-clockwise rotation:
port plate is rotated through 180°

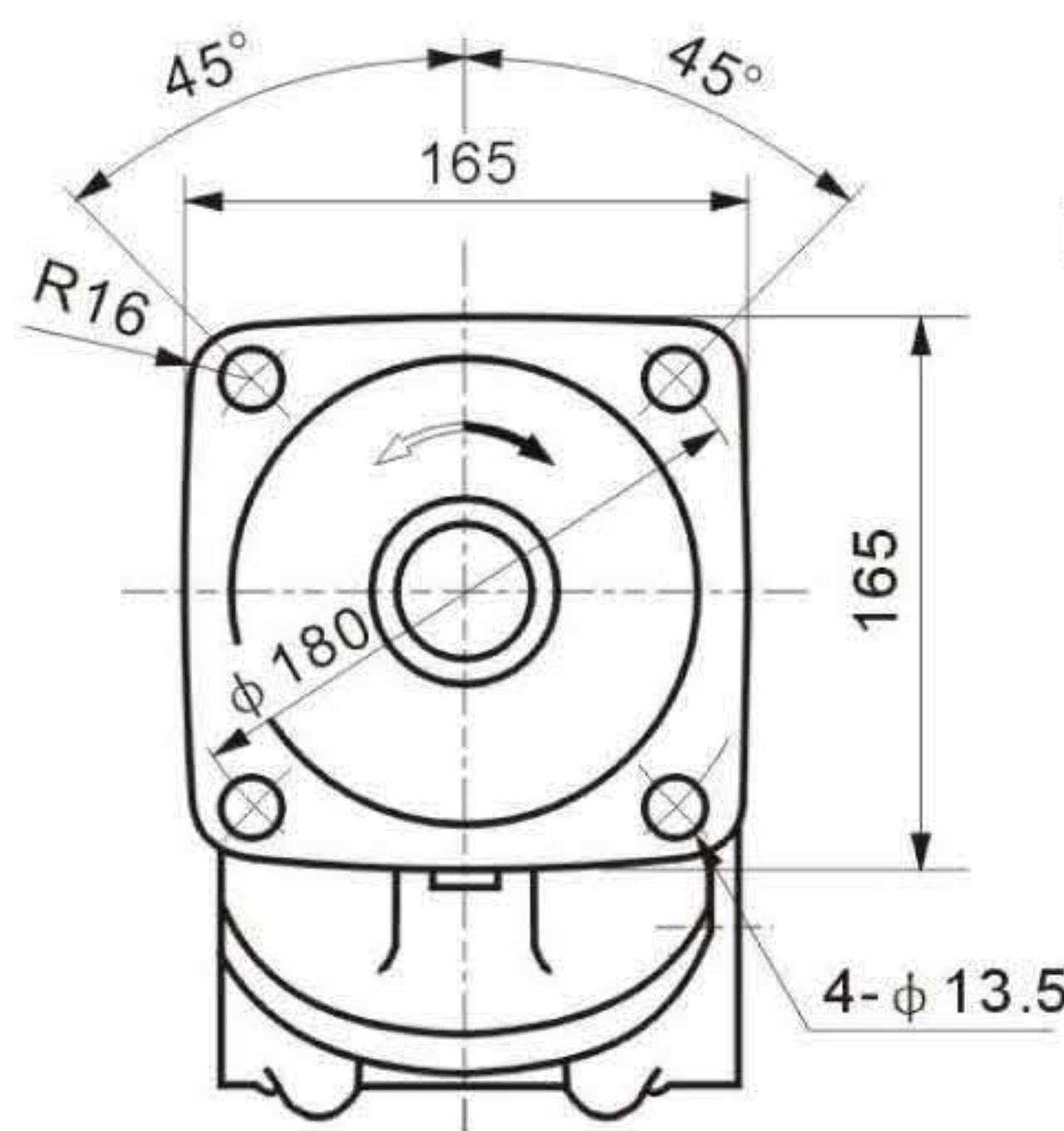
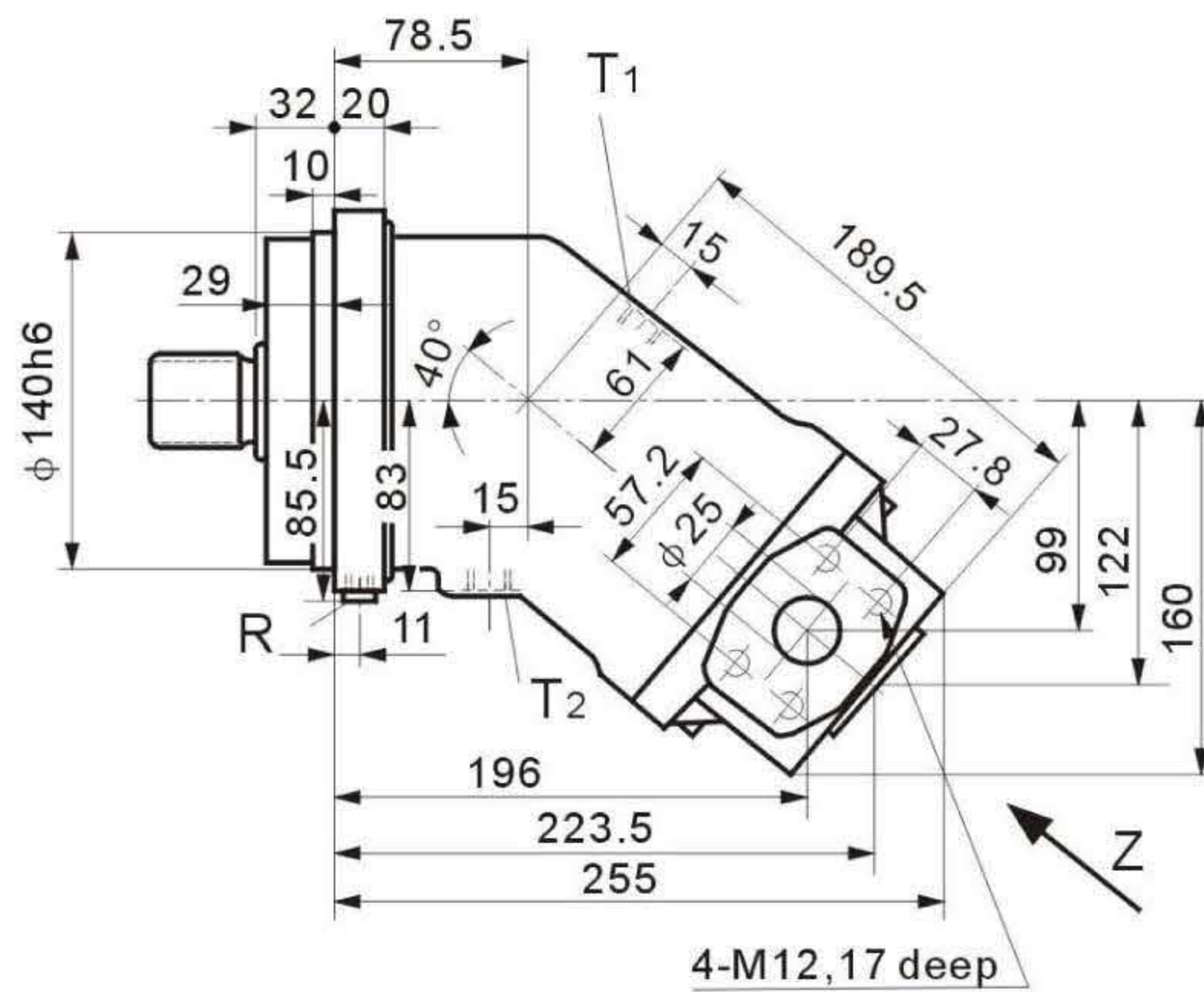

View Z

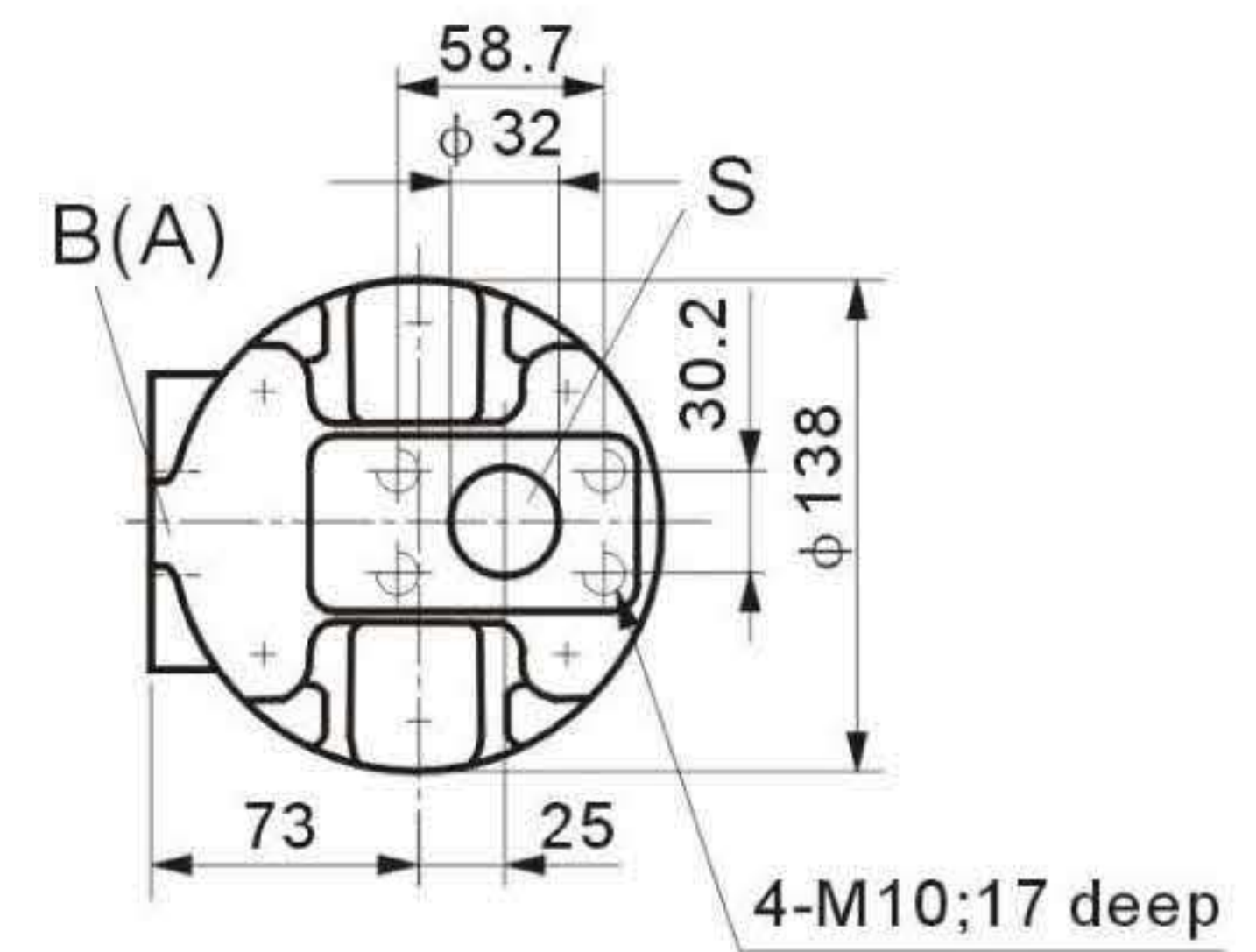

Ports

B(A)	Service line port (high pressure series)	SAE 1"
S	Suction port (standard pressure series)	SAE 1 1/4"
T ₁ , T ₂	Case drain ports (T ₁ plugged)	M18×1.5
R	Air bleed (plugged)	M12×1.5

Shaft ends

Sizes 80,90
A Splined shaft DIN 5480
W40×2×30×18×9g
PN = 40 MPa

Size 80
Z Splined shaft DIN 5480
W35×2×30×16×9g
PN = 40 MPa

Sizes 80,90
B Parallel keyed shaft,
DIN 6885, AS12×8×56
PN = 35 MPa

Size 80
P Parallel keyed shaft
DIN 6885, AS10×8×56
PN = 35 MPa

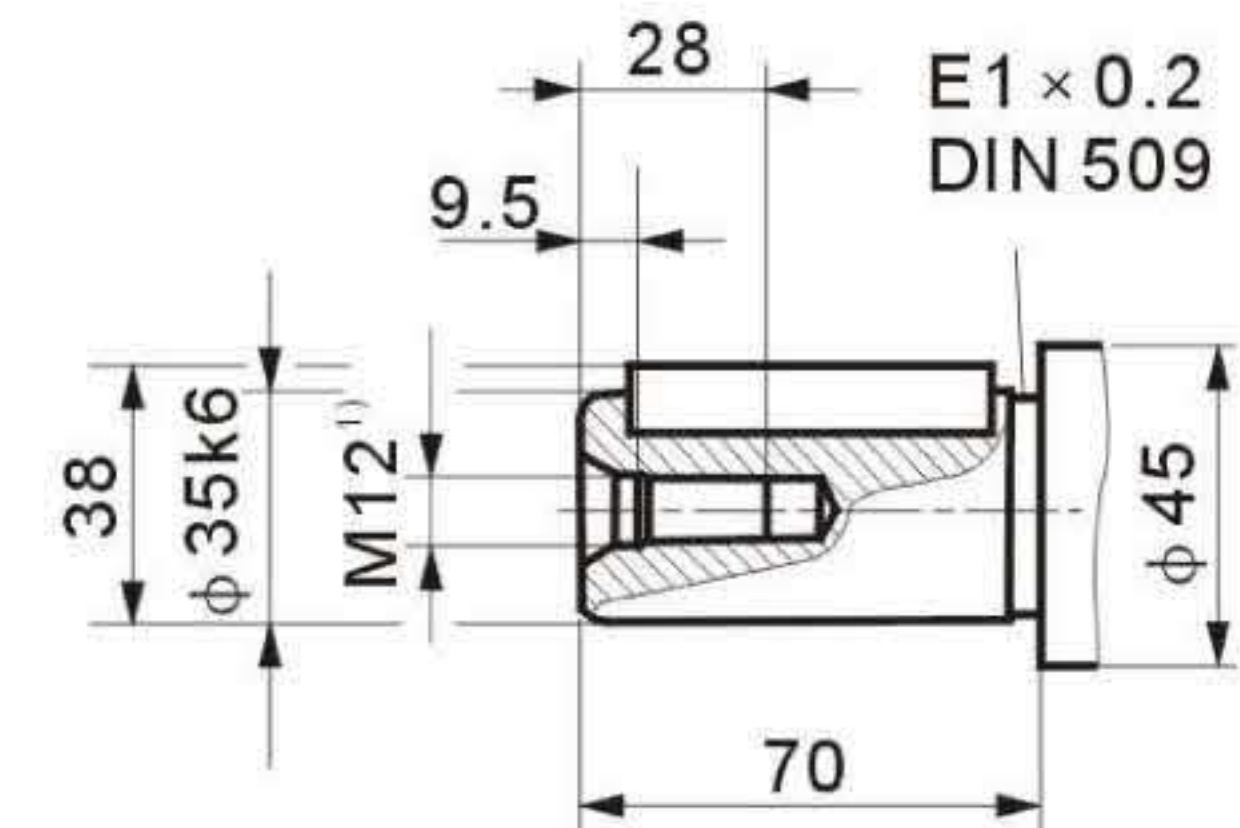
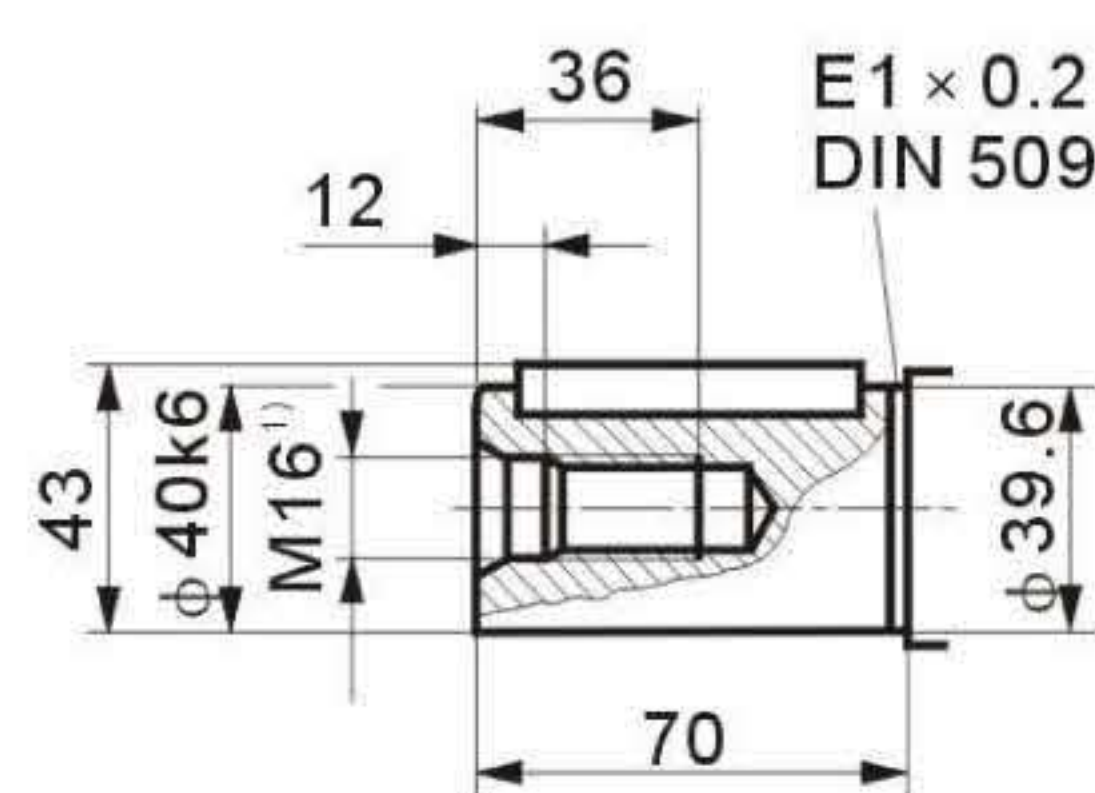
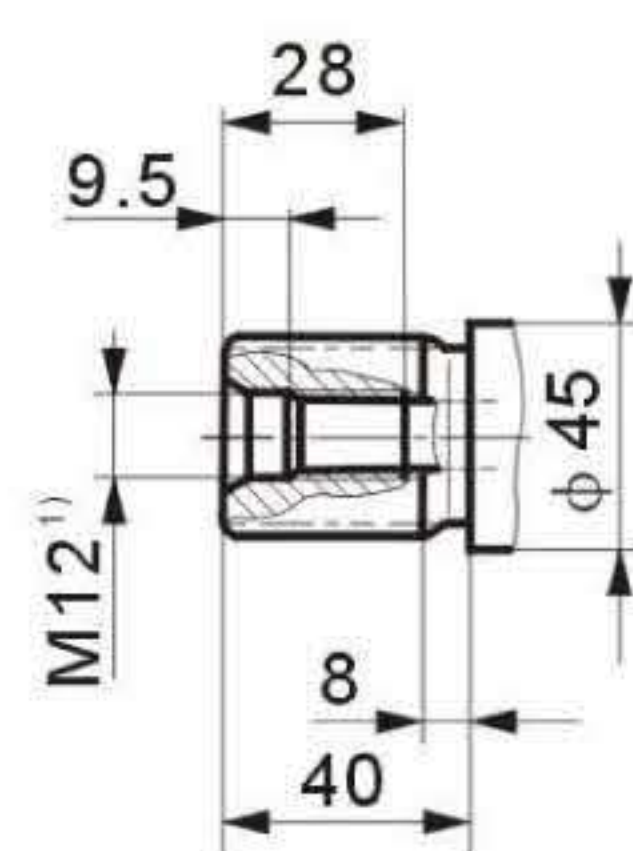
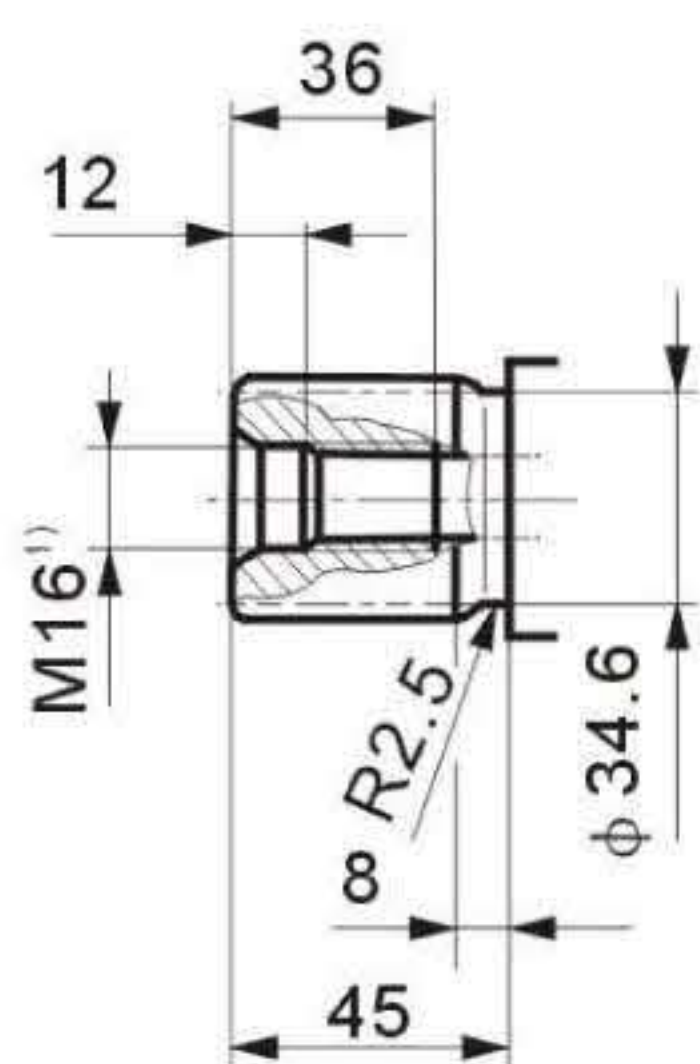

1) centering bore according to DIN 332 (thread according to DIN 13)

Installation dimensions

A2F056/61R-※B05
A2F063/61R-※B05

Counter-clockwise rotation:
port plate is rotated through 180°

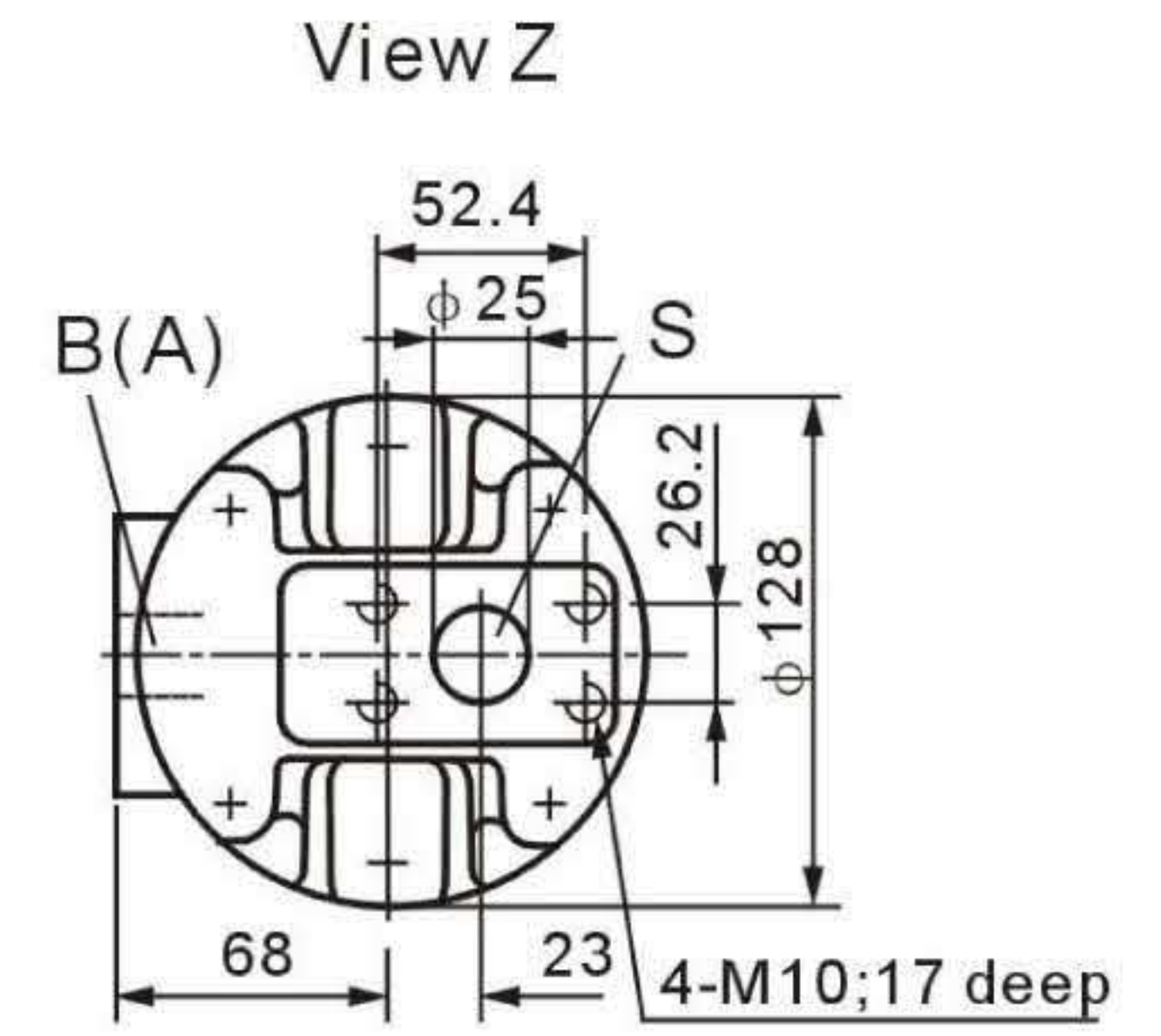
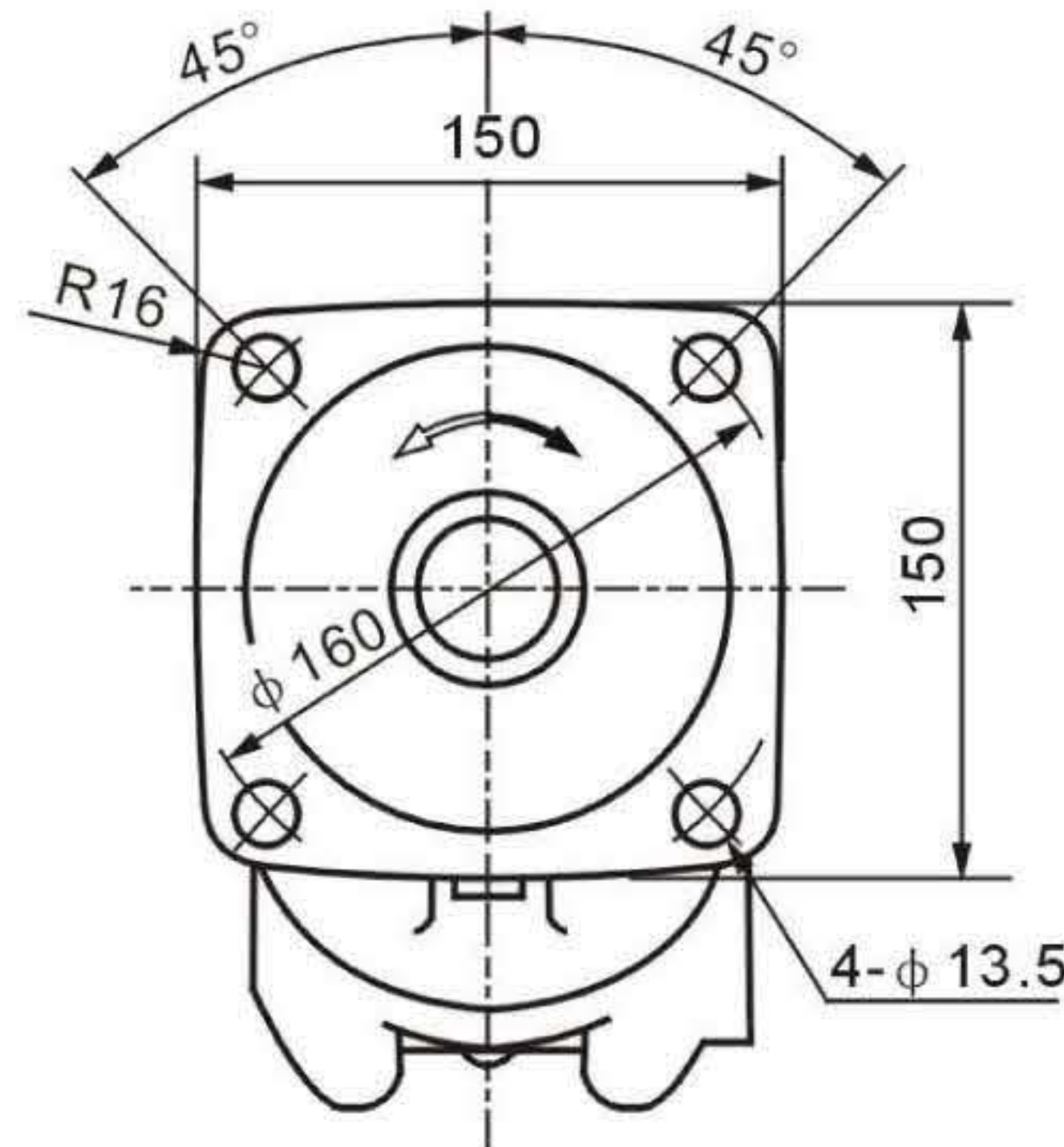
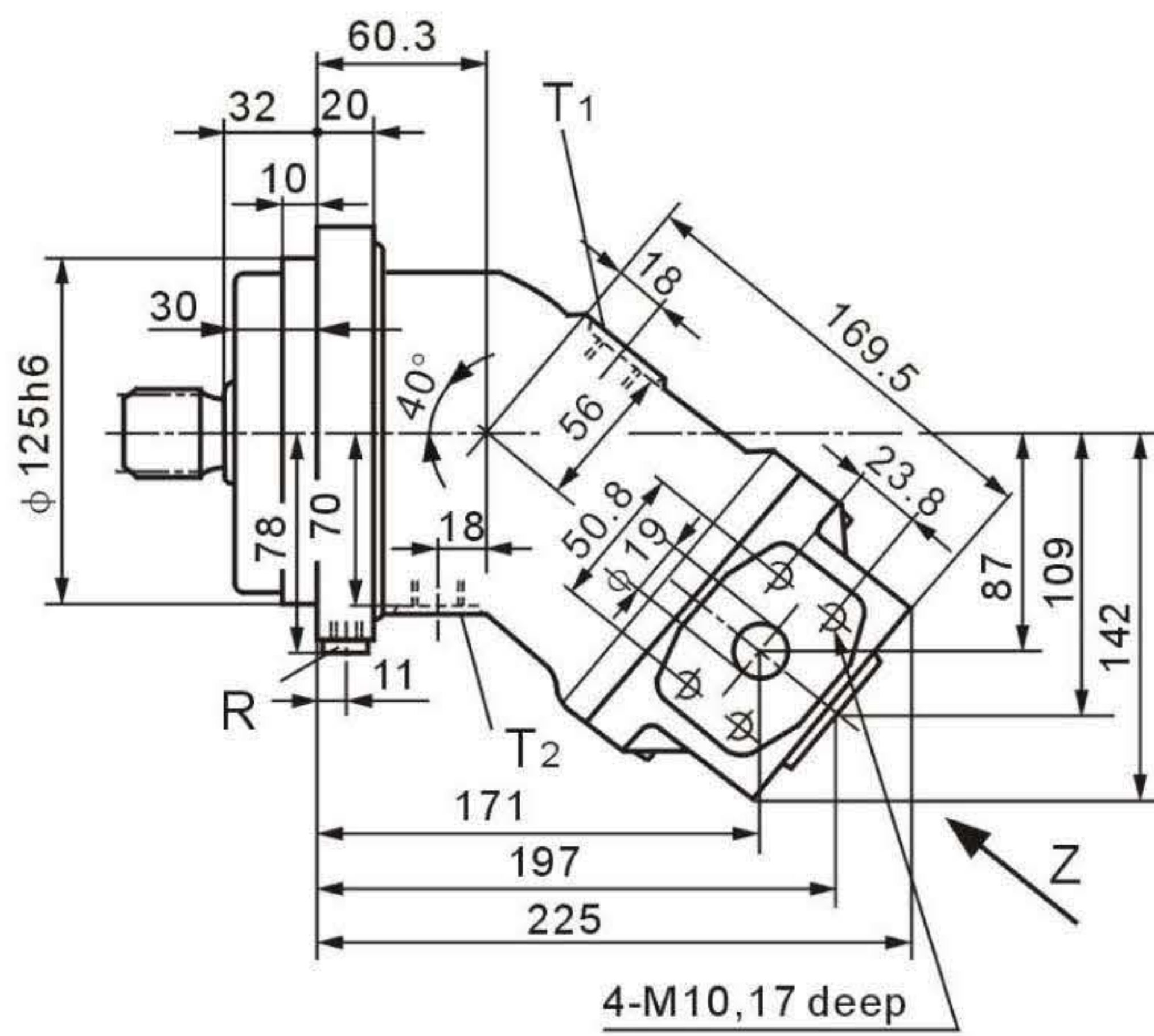

Ports

B(A)	Service line port (high pressure series)	SAE 3/4"
S	Suction port (standard pressure series)	SAE 1"
T ₁ , T ₂	Case drain ports (T ₁ plugged)	M18×1.5
R	Air bleed (plugged)	M12×1.5

Shaft ends

Sizes 56,63
A Splined shaft DIN 5480
W35×2×30×16×9g
PN = 40 MPa

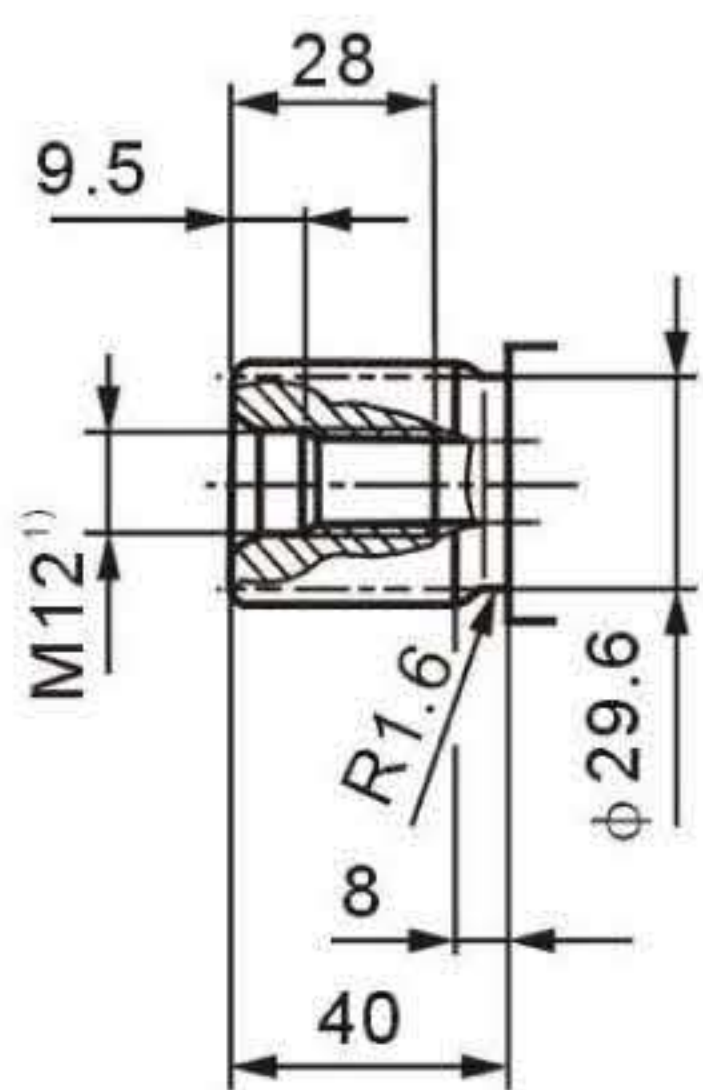

Size 56
Z Splined shaft DIN 5480
W30×2×30×14×9g
PN = 35 MPa

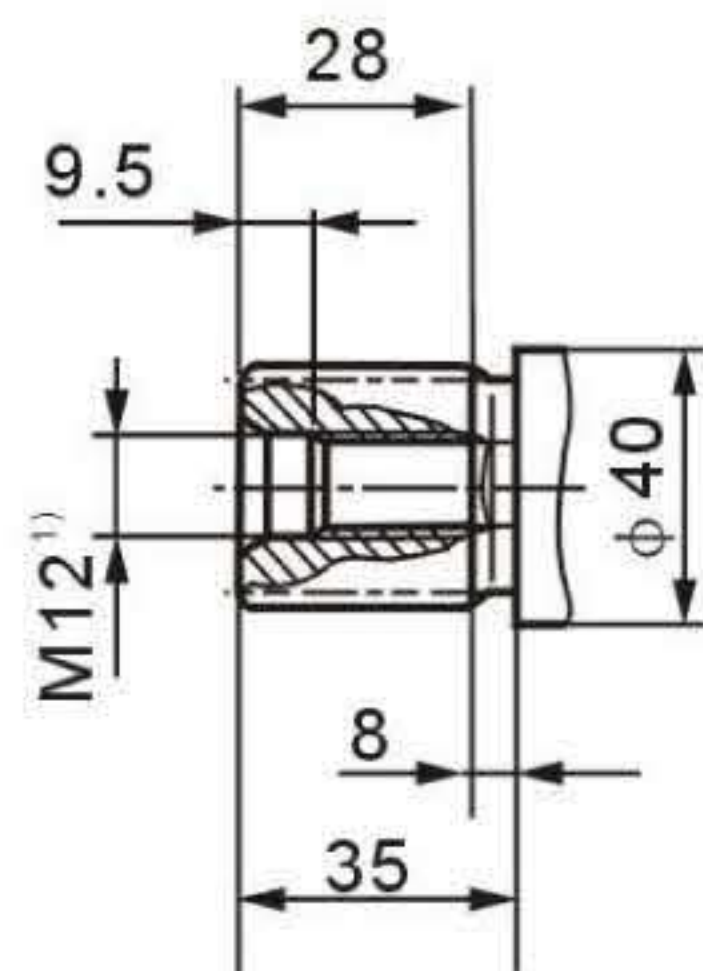

Sizes 56,63
B Parallel keyed shaft,
DIN 6885, AS10×8×50
PN = 35 MPa

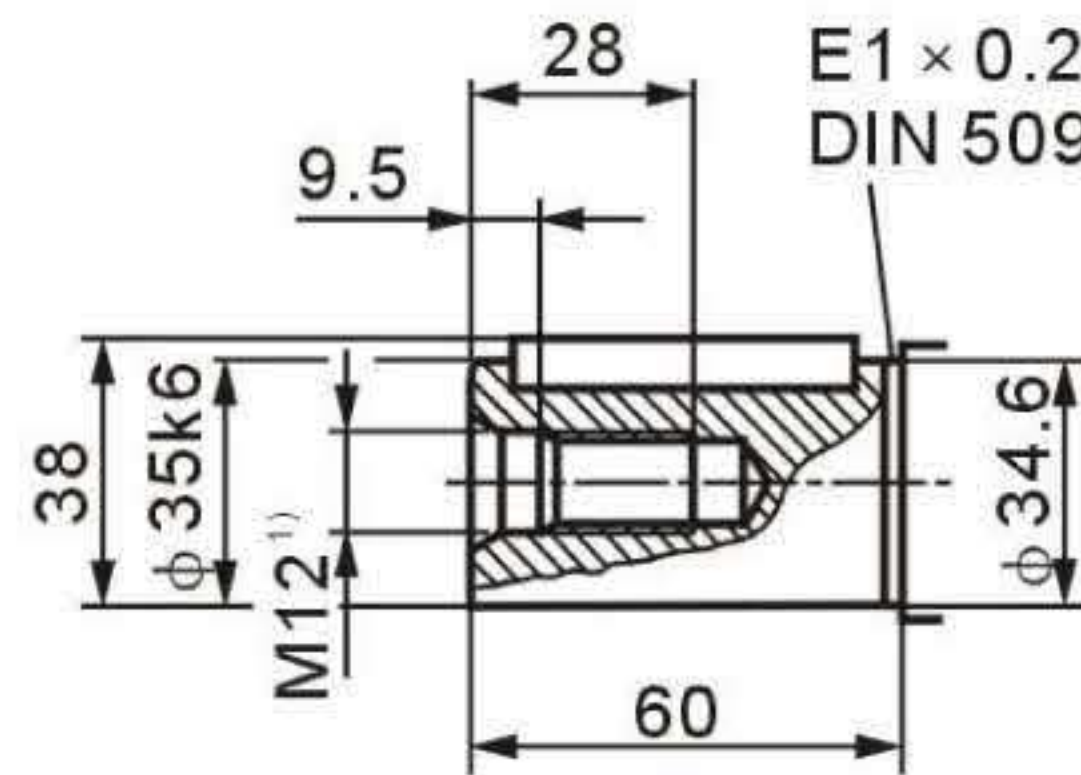

Size 56
P Parallel keyed shaft
DIN 6885, AS8×7×50
PN = 35 MPa

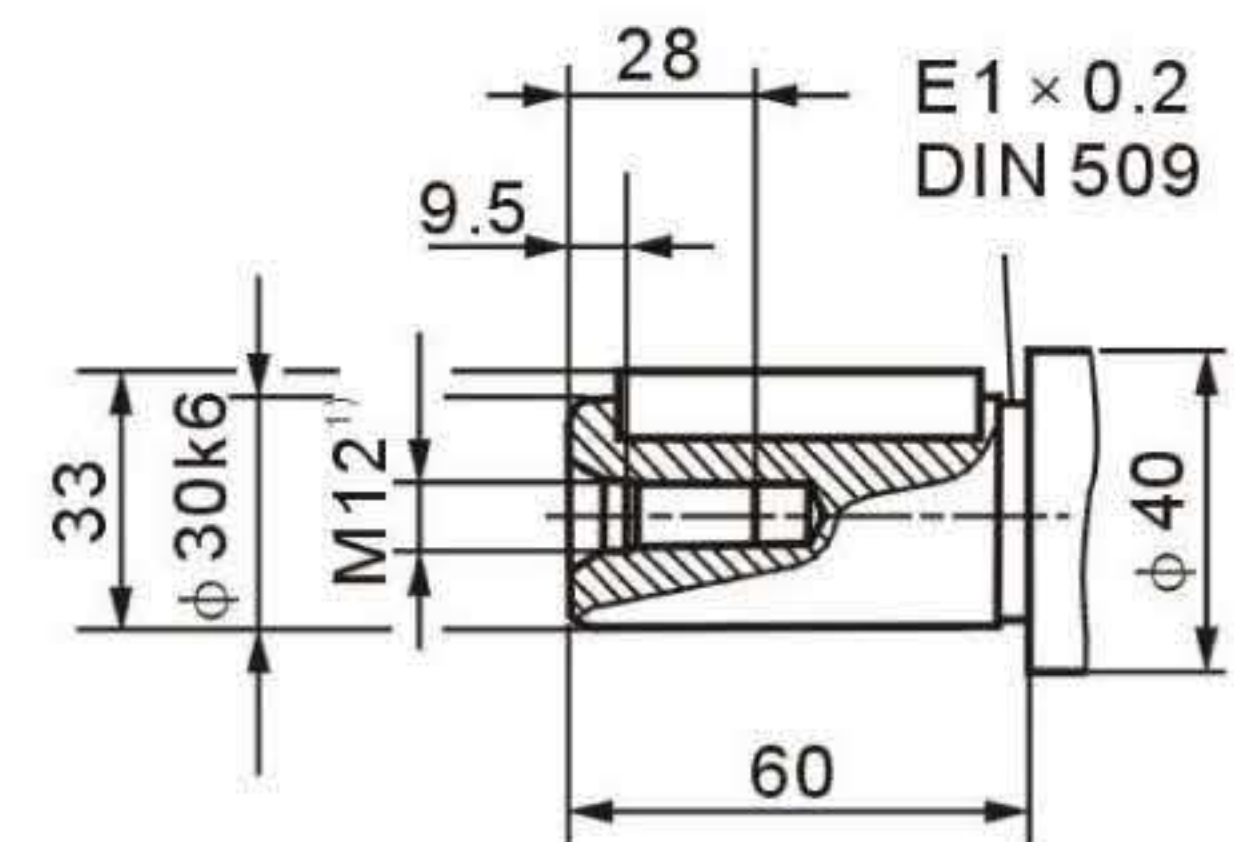

1) centering bore according to DIN 332 (thread according to DIN 13)

Installation dimensions

A2F045/61R-※B05

Counter-clockwise rotation:
port plate is rotated through 180°

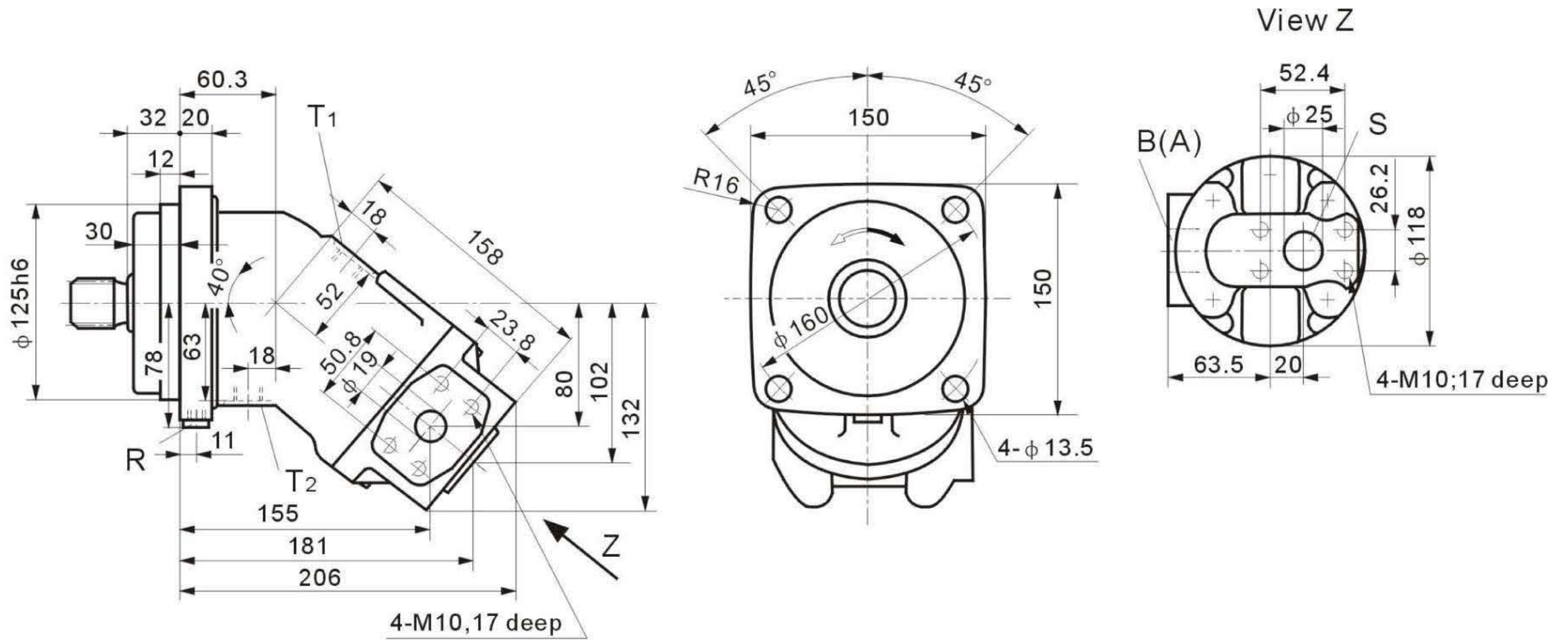

Ports

B(A)	Service line port (high pressure series)	SAE 3/4"
S	Suction port (standard pressure series)	SAE 1"
T ₁ , T ₂	Case drain ports (T ₁ plugged)	M18×1.5
R	Air bleed (plugged)	M12×1.5

Shaft ends

Size 45
Z Splined shaft DIN 5480
W30×2×30×14×9g
PN = 40 MPa

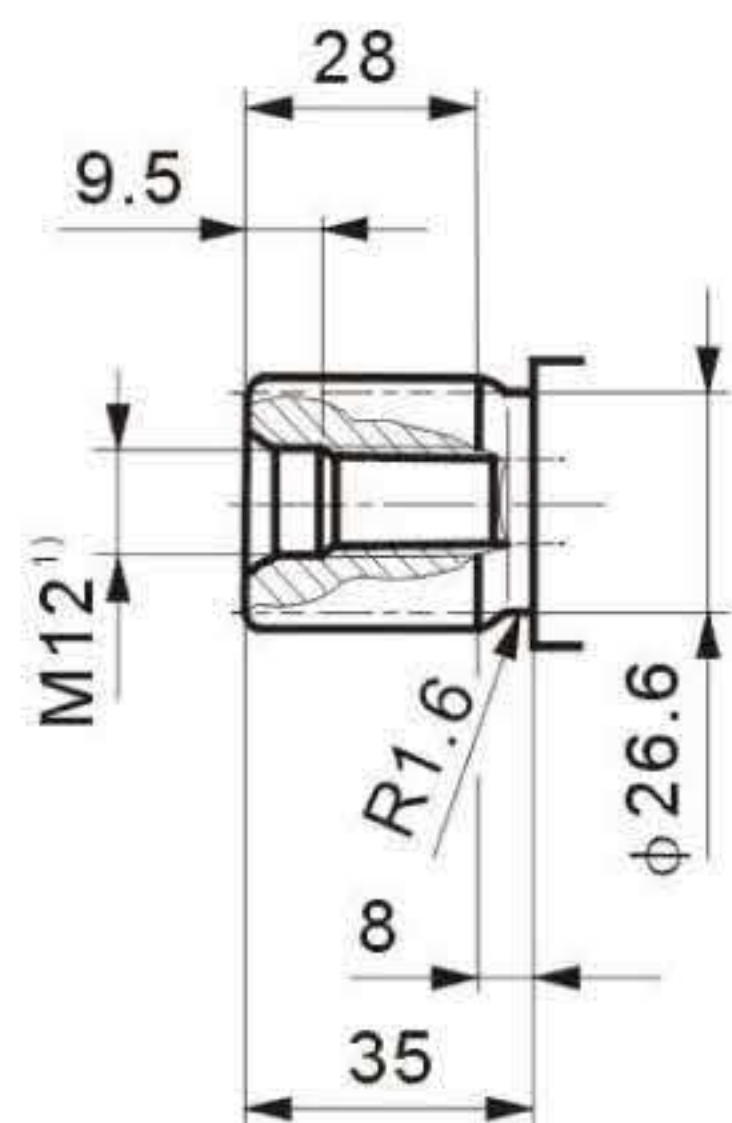

Size 45
P Parallel keyed shaft
DIN 6885, AS8×7×50
PN = 35 MPa

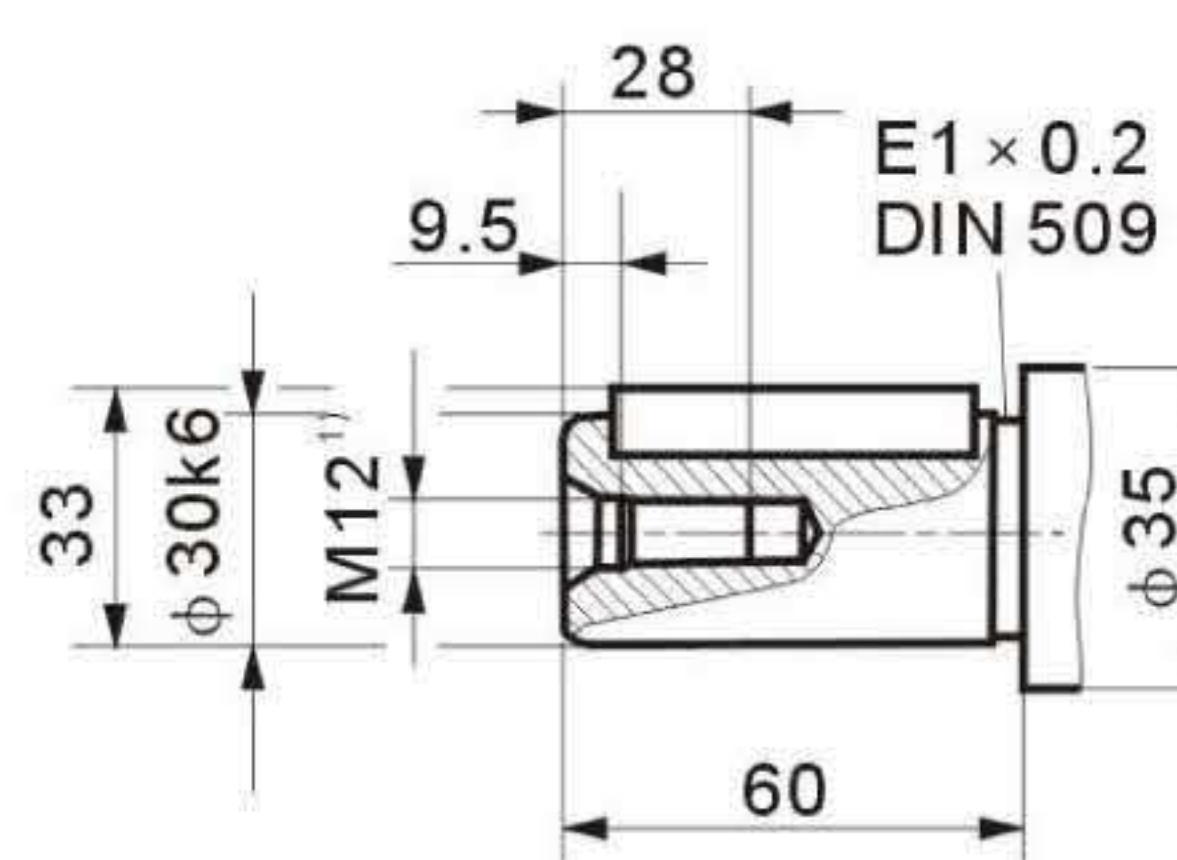

1) centering bore according to DIN 332 (thread according to DIN 13)

Installation dimensions

A2F023/61R-※B05
 A2F028/61R-※B05
 A2F032/61R-※B05

Counter-clockwise rotation:
 port plate is rotated through 180°

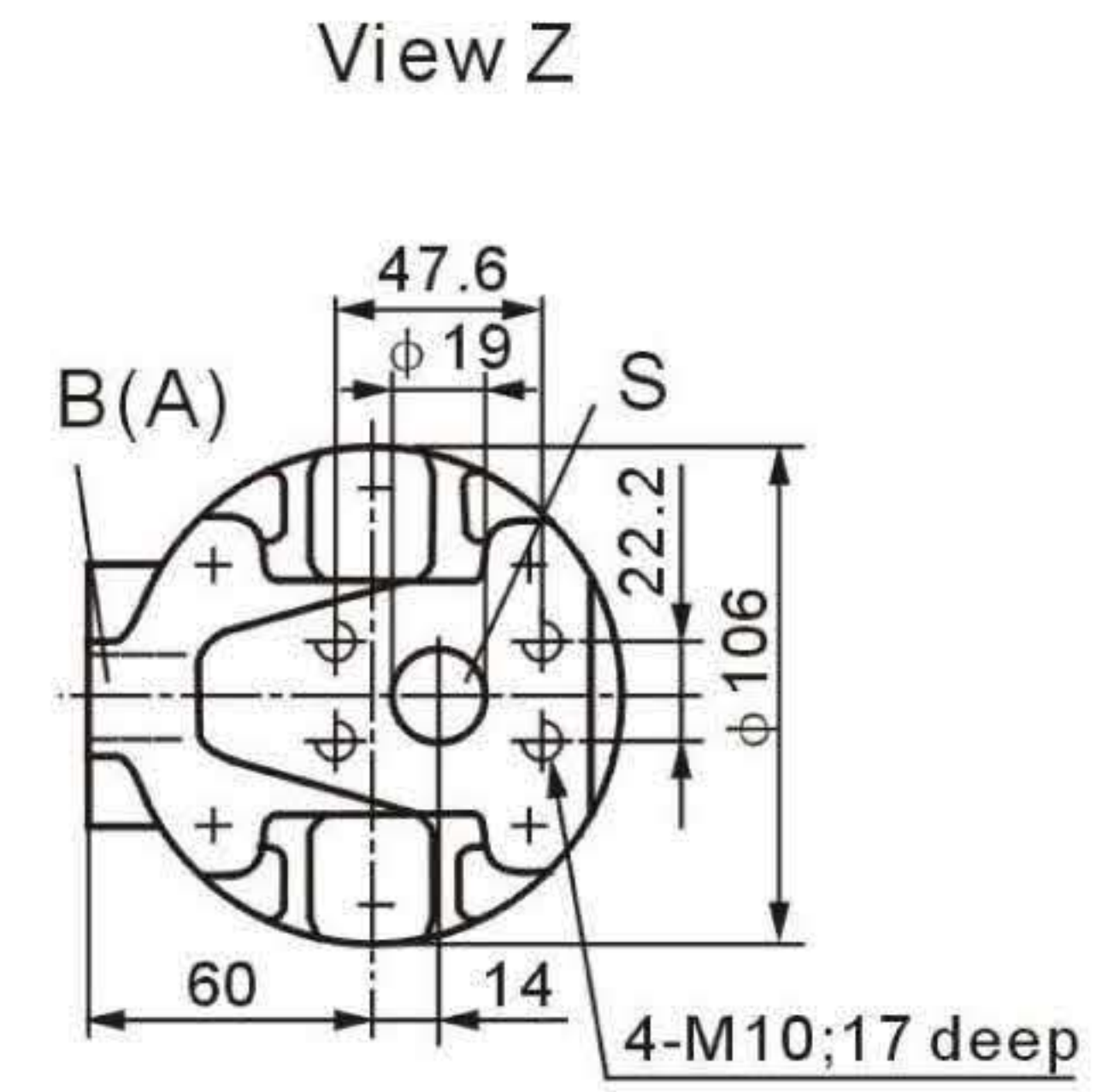
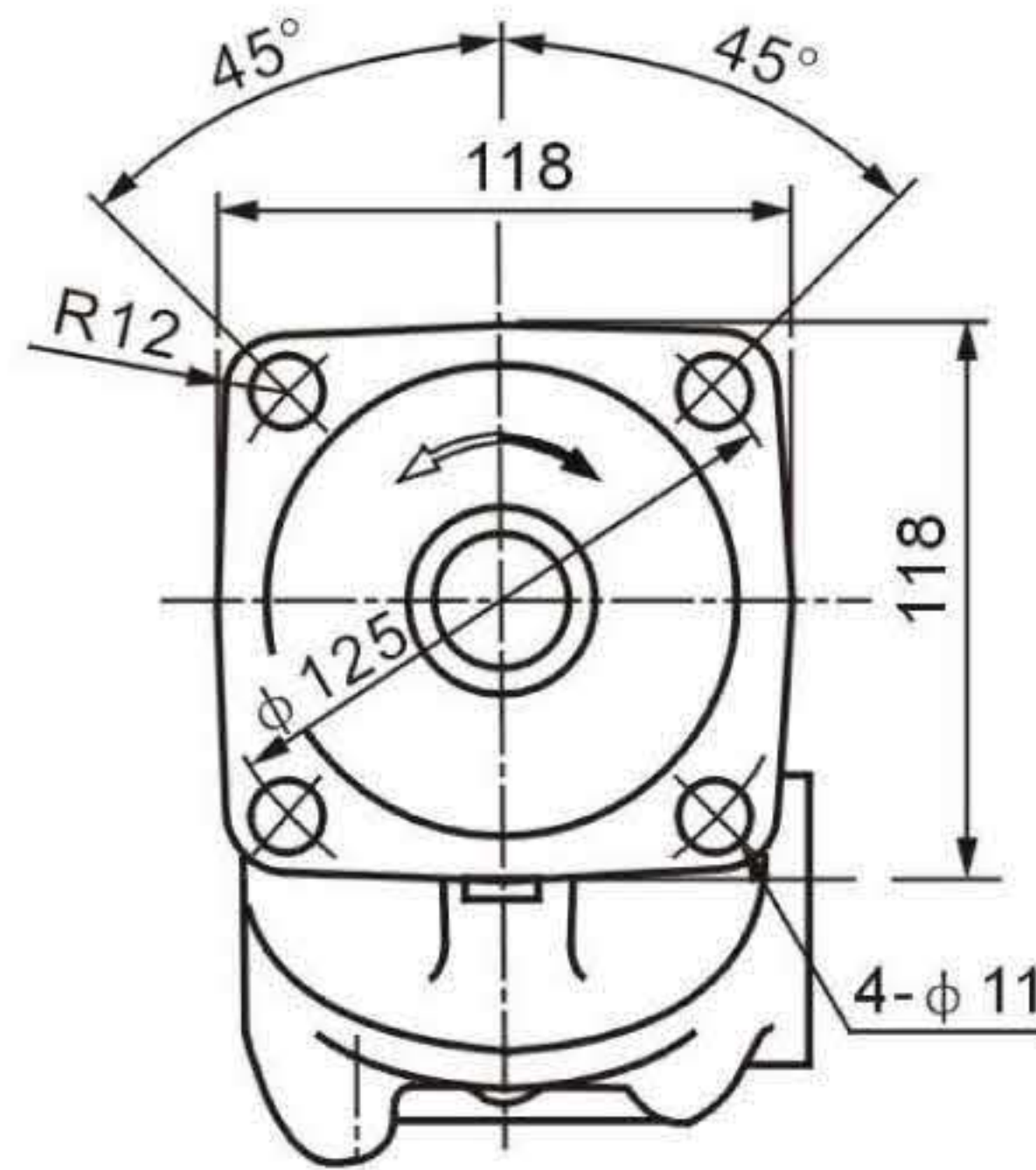
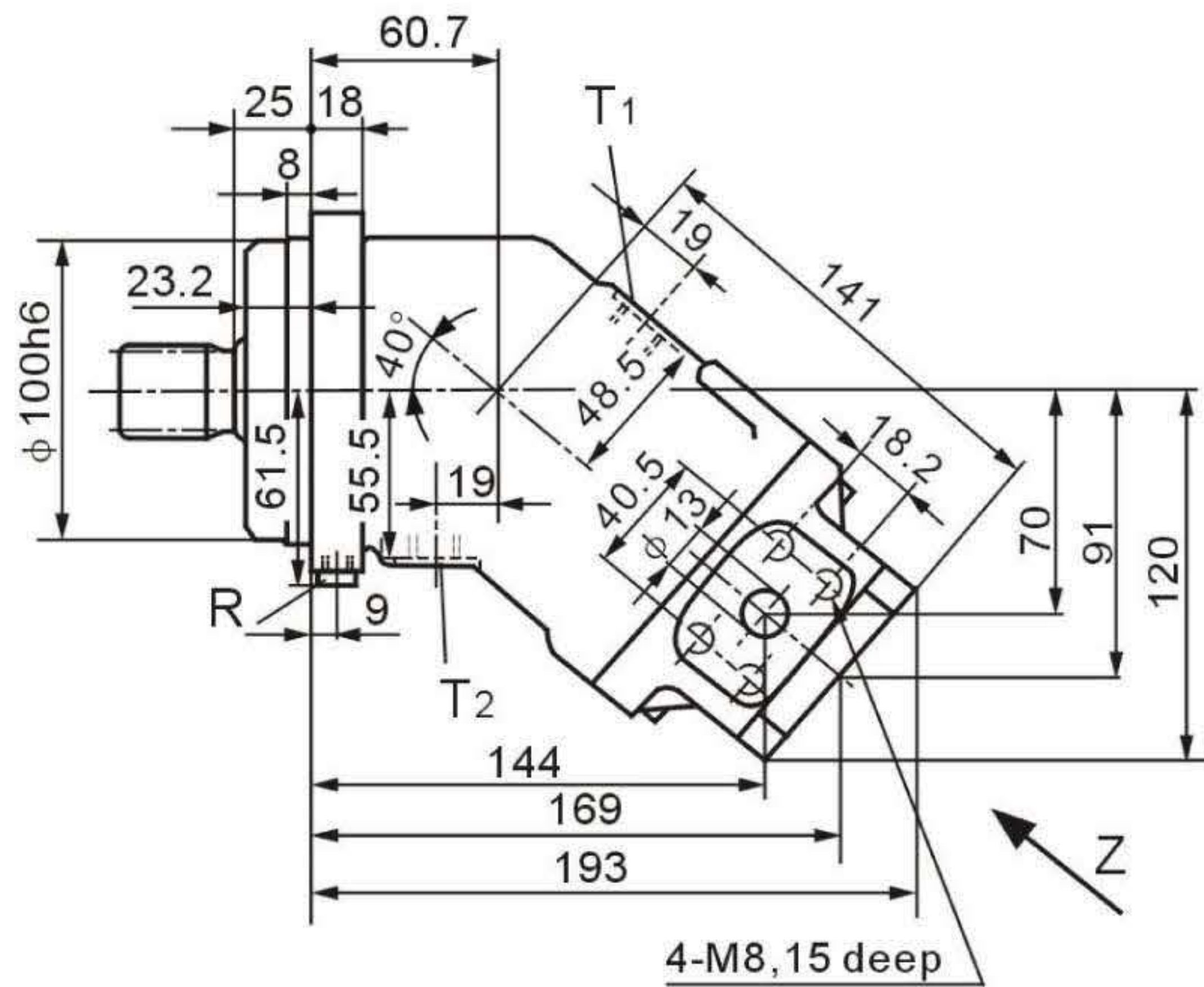

Ports

B(A)	Service line port (high pressure series)	SAE 1/2"
S	Suction port (standard pressure series)	SAE 3/4"
T ₁ , T ₂	Case drain ports (T ₁ plugged)	M16×1.5
R	Air bleed (plugged)	M10×1

Shaft ends

Sizes 23,28,32
 A Splined shaft DIN 5480
 W30×2×30×14×9g
 P_N = 40 MPa

Sizes 23,28
 Z Splined shaft DIN 5480
 W25×1.25×30×18×9g
 P_N = 40 MPa

Sizes 23,28,32
 B Parallel keyed shaft,
 DIN 6885, AS8×7×40
 P_N = 35 MPa

Sizes 23,28
 P Parallel keyed shaft
 DIN 6885, AS8×7×40
 P_N = 35 MPa

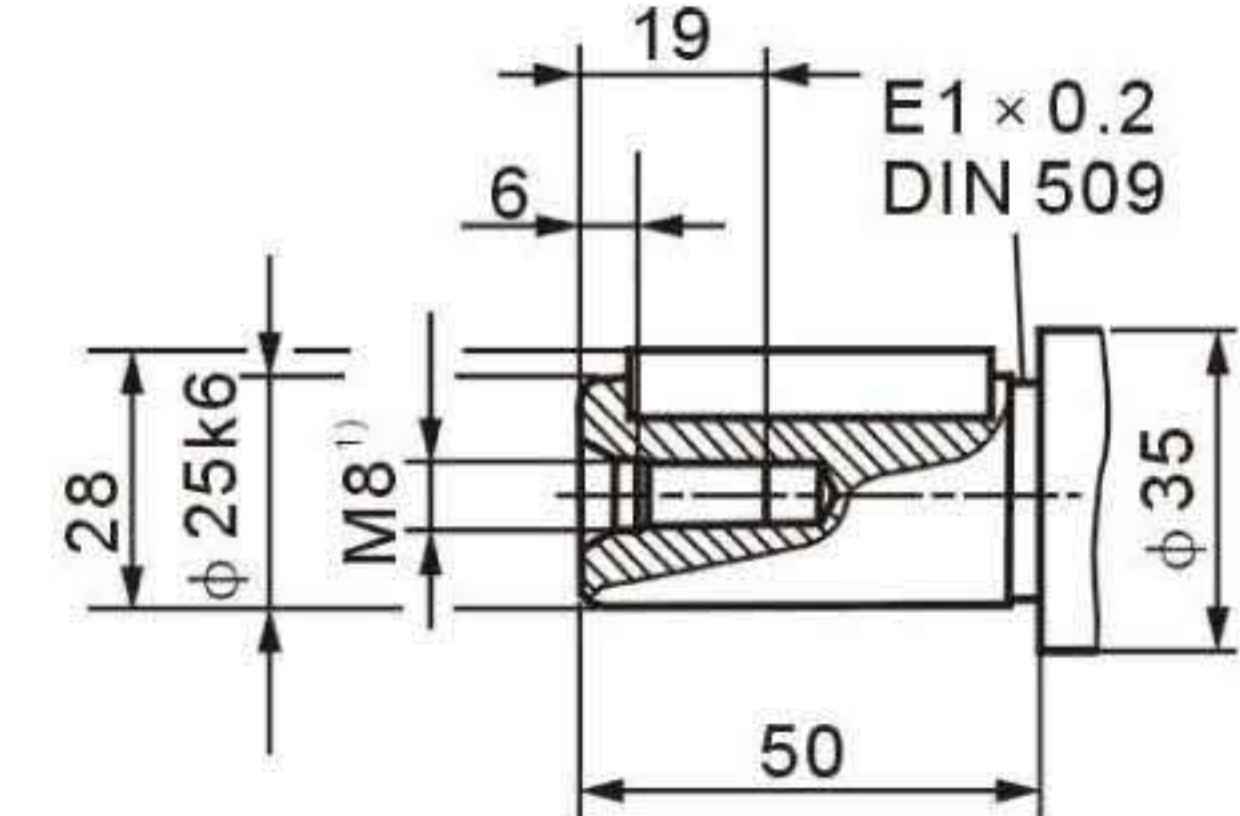
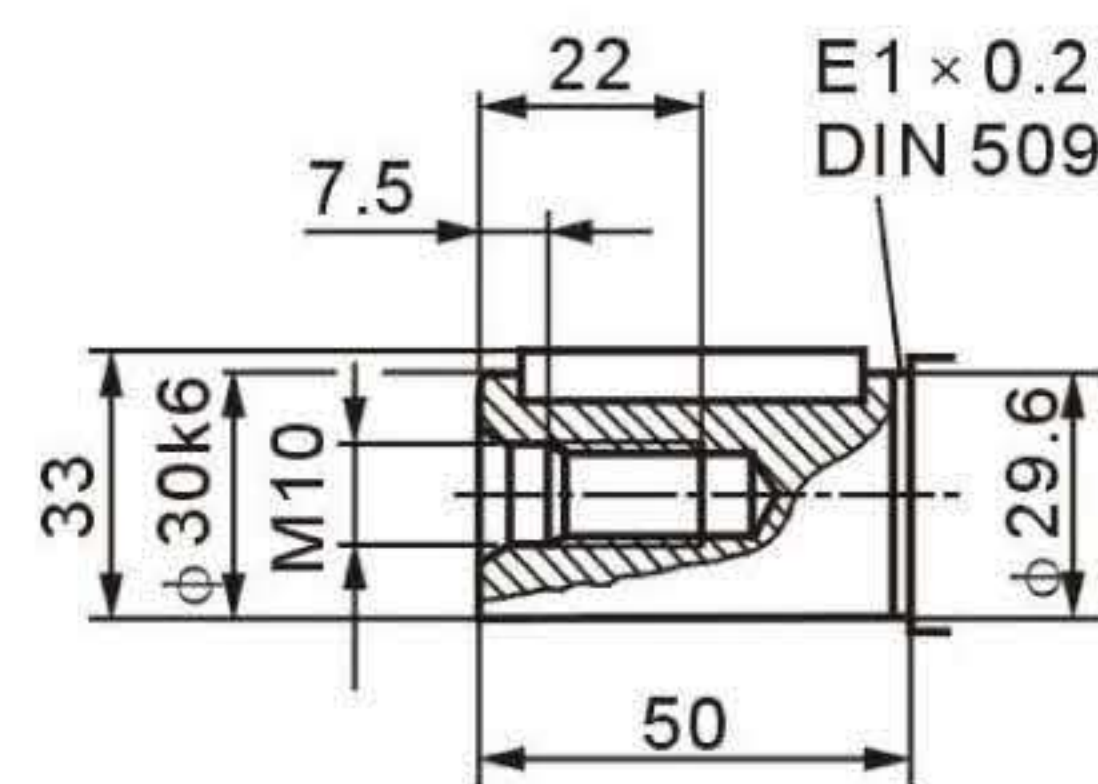
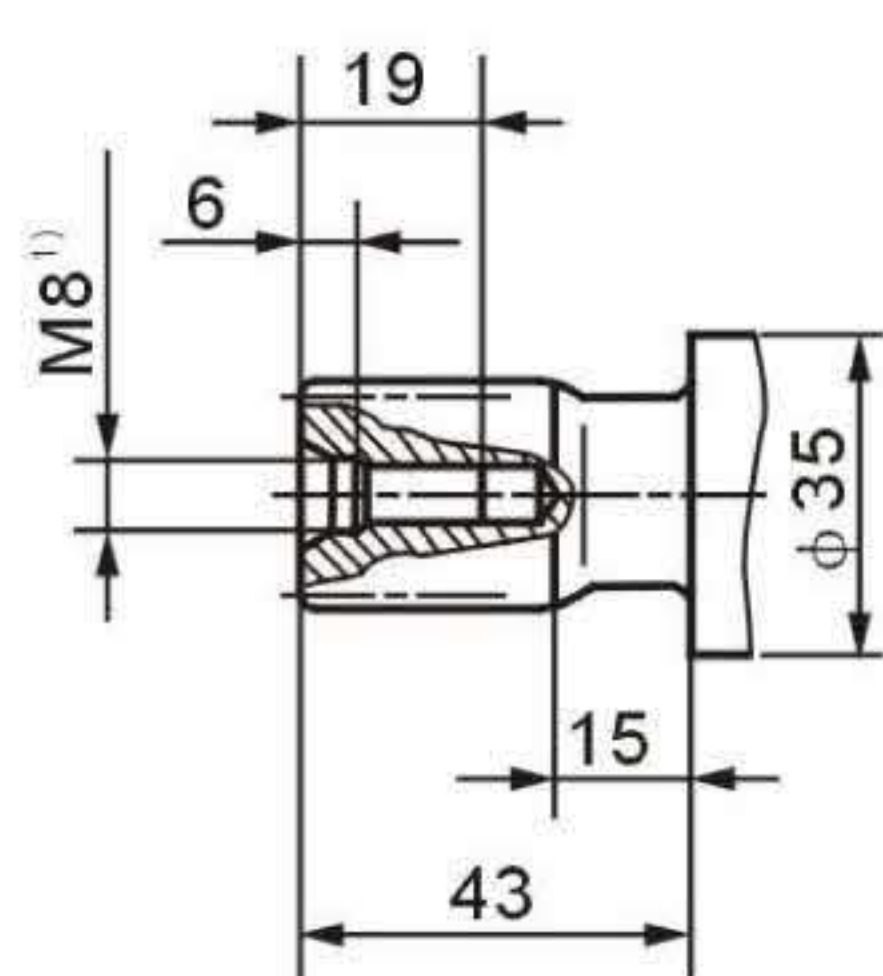
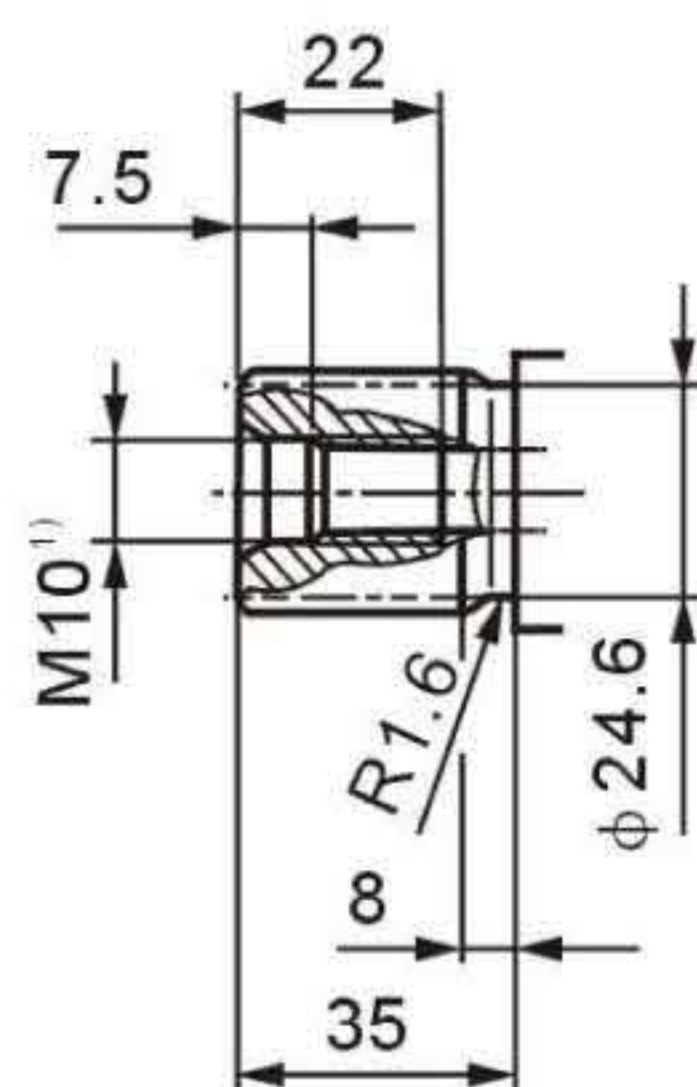

1) centering bore according to DIN 332 (thread according to DIN 13)

Installation dimensions

A2F010/61R-※B06
 A2F012/61R-※B06
 A2F016/61R-※B06

Counter-clockwise rotation:
 port plate is rotated through 180°

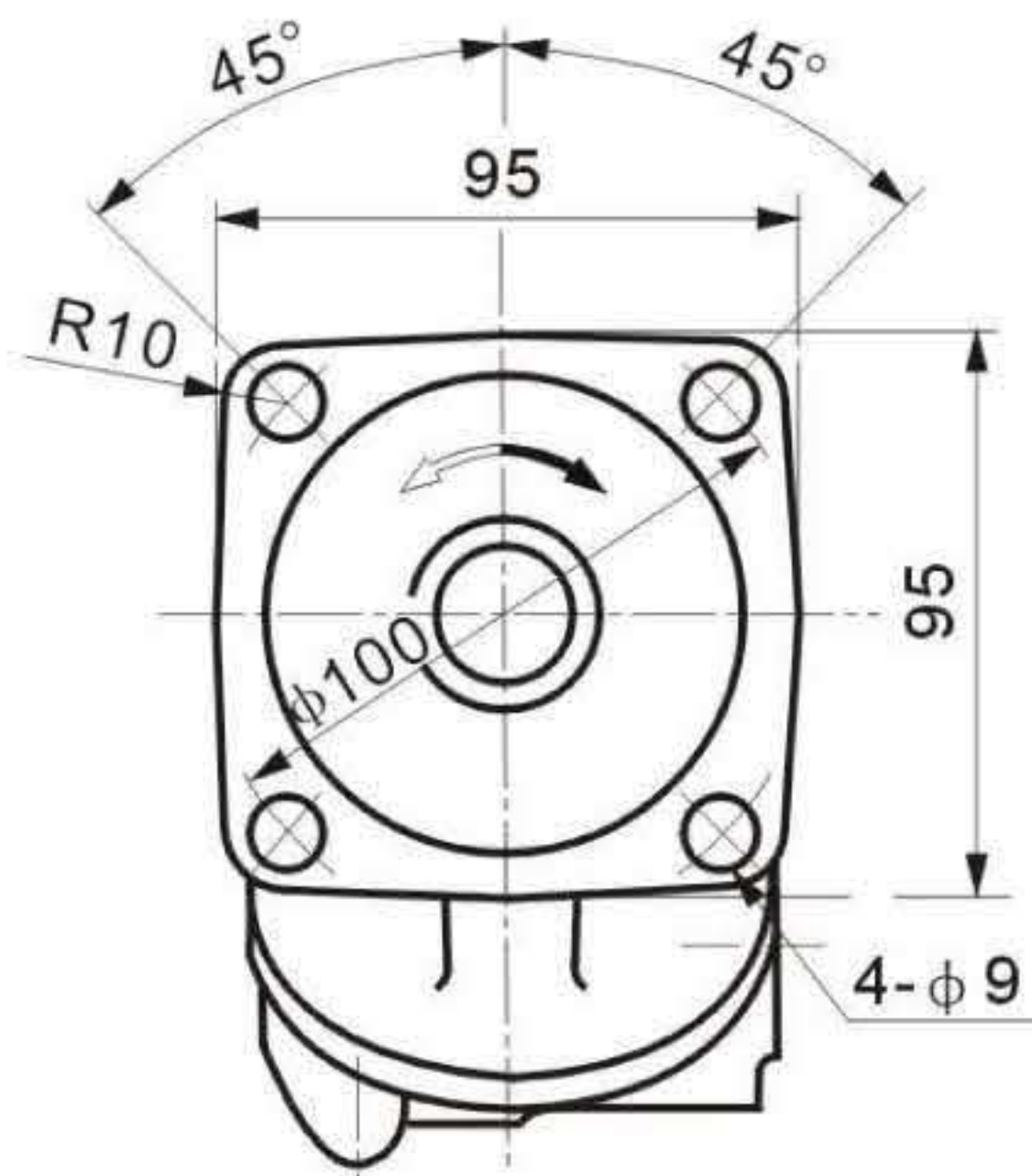
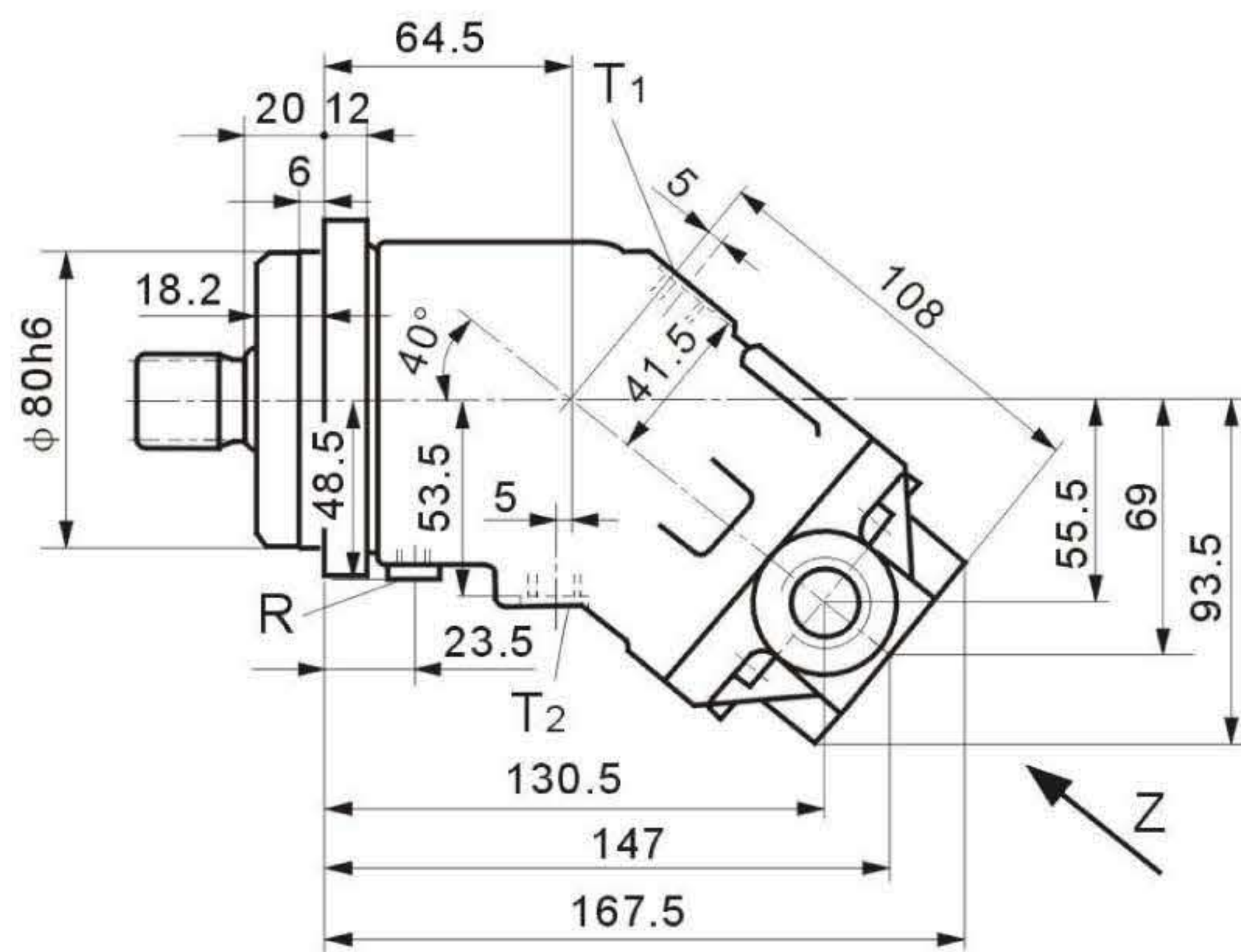

View Z

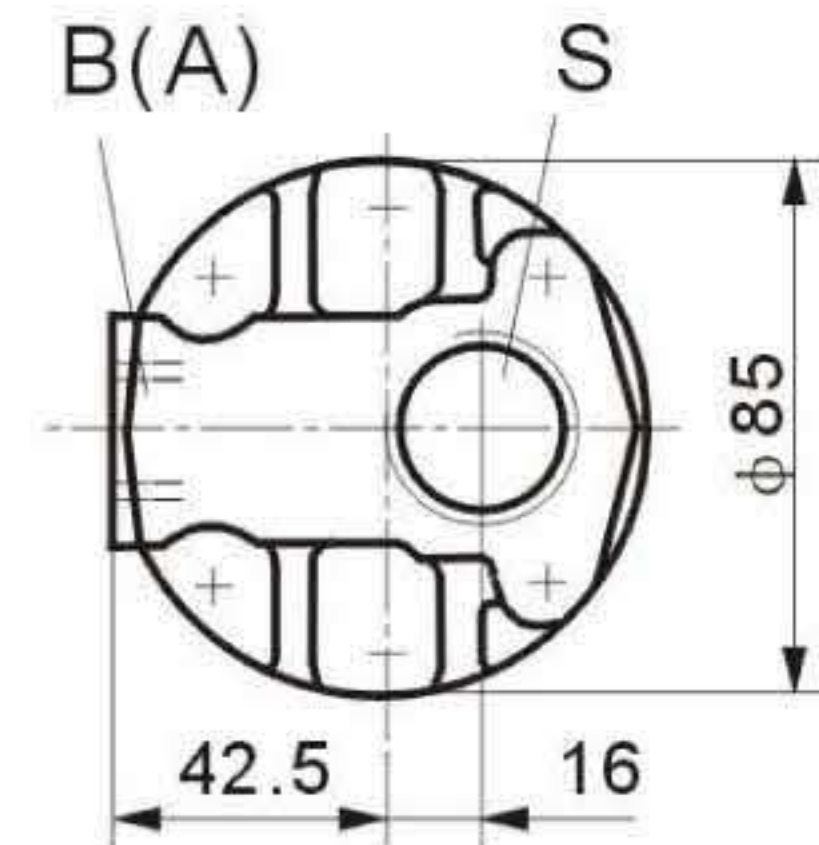

Ports

B(A)	Service line port	M22×1.5
S	Suction port	M33×2
T ₁ , T ₂	Case drain ports (T ₁ plugged)	M12×1.5
R	Air bleed (plugged)	M8×1

Shaft ends

Sizes 10,12,16
 A Splined shaft DIN 5480
 W25×1.25×30×18×9g
 P_N = 40 MPa

Sizes 10,12
 Z Splined shaft DIN 5480
 W20×1.25×30×14×9g
 P_N = 40 MPa

Sizes 10,12,16
 B Parallel keyed shaft,
 DIN 6885, AS8×7×32
 P_N = 35 MPa

Sizes 10,12
 P Parallel keyed shaft
 DIN 6885, A6×6×32
 P_N = 35 MPa

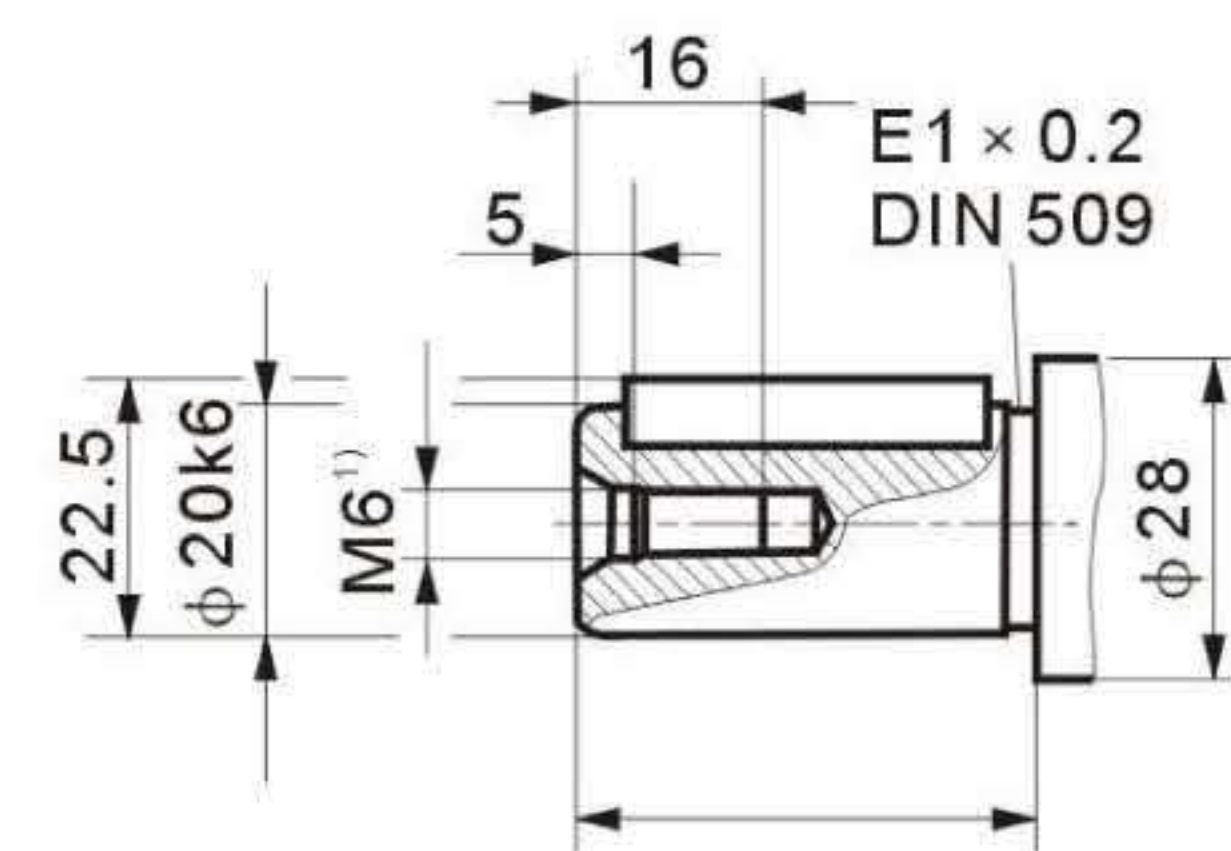
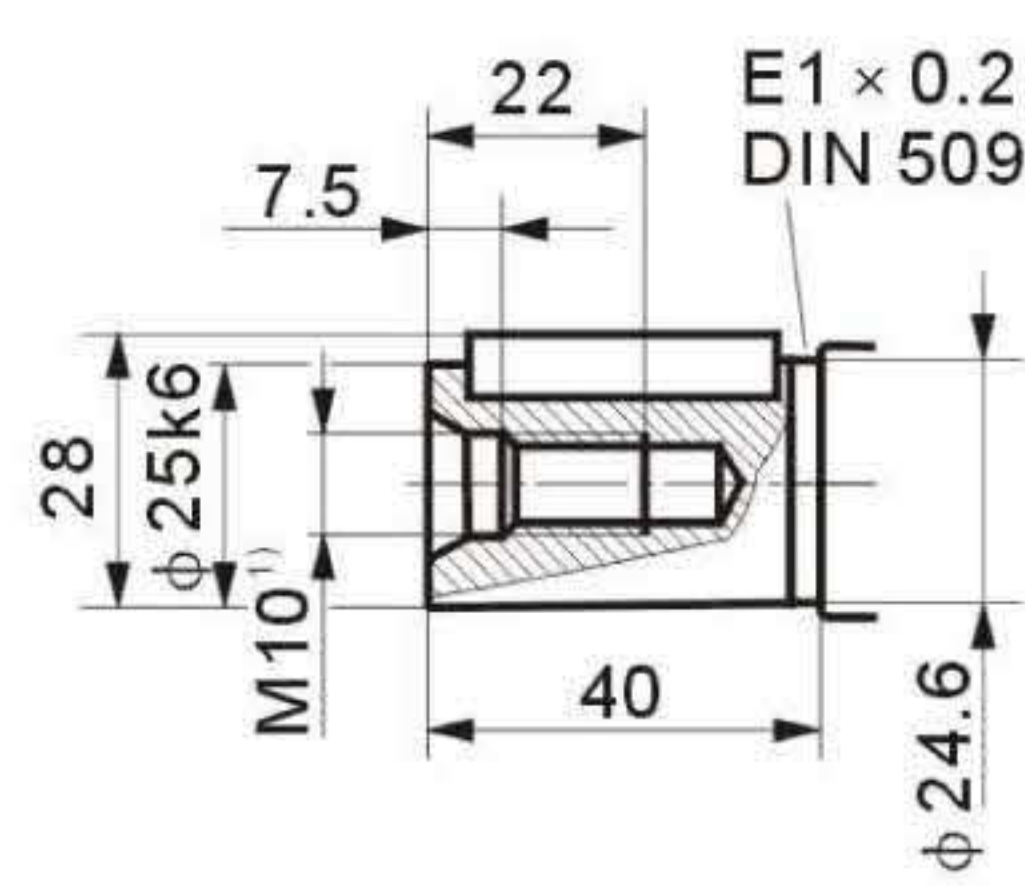
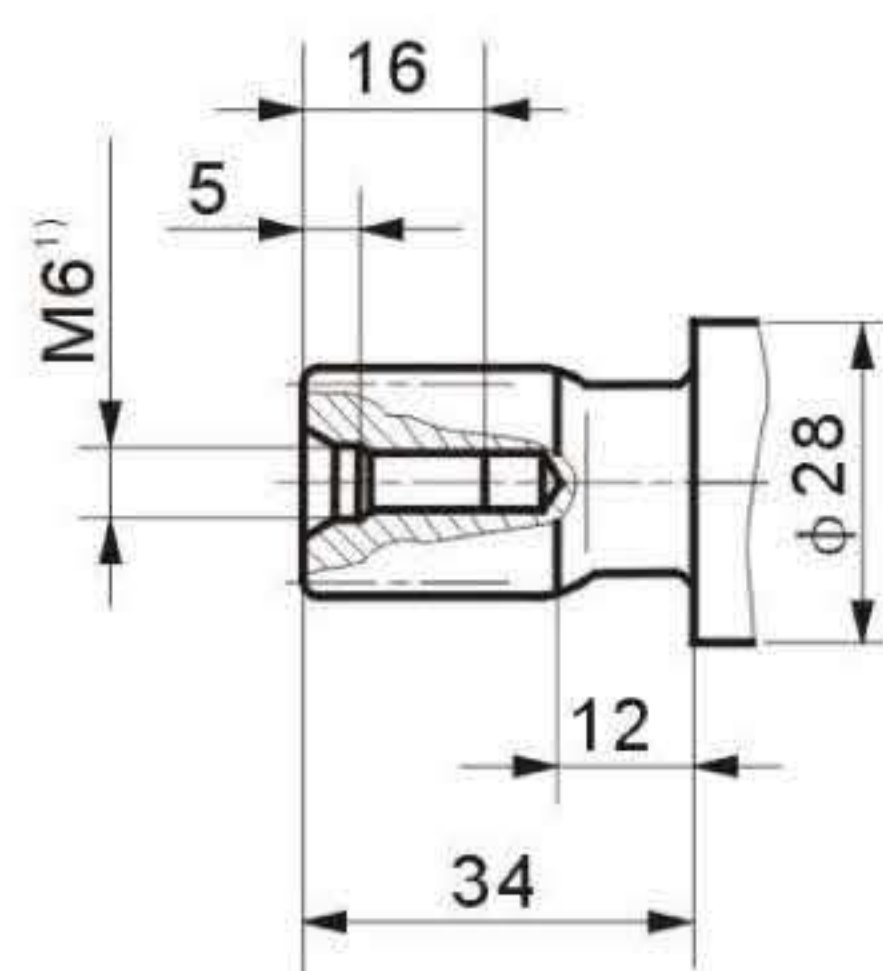
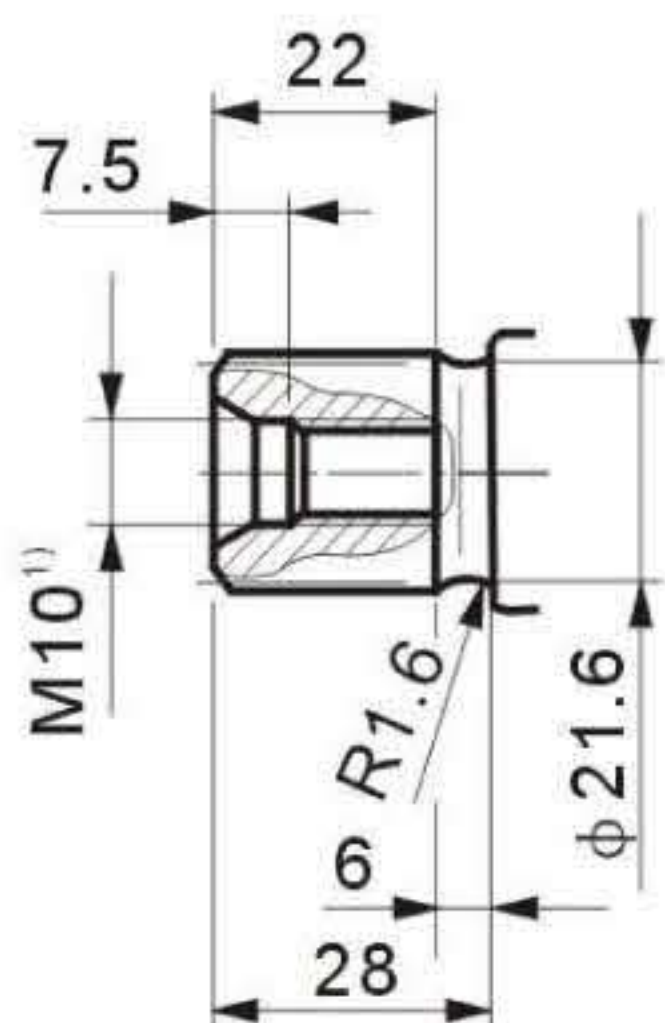

1) centering bore according to DIN 332 (thread according to DIN 13)

Technical Data

- Table of values (theoretical values, ignoring η_{min} and η_v ; values rounded)

Size			10	12	16	23	28	32	45
Displacement	V_g	mL/r	10.3	12	16	22.9	28.1	32	45.6
Speed max	$N_{max}^{1)}$	rpm	3150	3150	3150	2500	2500	2500	2240
	$n_{max\ limit}^{2)}$	rpm	6000	6000	6000	4750	4750	4750	4250
Flow max.	at n_{max}	q_{vmax}	L/min	32.4	37.8	50	57	70	102
Power at	$\Delta P=35\ MPa$	P_{max}	Nm/MPa	18.9	22	29.2	33	41	59.5
	$\Delta P=40\ MPa$	P_{max}	Nm	21.6	25	34	38	47	68
Torque at	$\Delta P=35\ MPa$	T	Nm	57	67	88	126	156	254
	$\Delta P=40\ MPa$	T	Nm	65	76	101	145	178	290
Filling capacity		L	0.17	0.17	0.17	0.20	0.20	0.20	0.33
Mass(approx.)	m	kg	6	6	6	9.5	9.5	9.5	13.5

Size			56	63	80	90	107	125	160	180
Displacement	V_g	mL/r	56.1	63	80.4	90	106.7	125	160.4	180
Speed max	$N_{max}^{1)}$	rpm	2000	2000	1800	1800	1600	1600	1450	1450
	$n_{max\ limit}^{2)}$	rpm	3750	3750	3350	3350	3000	3000	2650	2650
Flow max.	at n_{max}	q_{vmax}	L/min	112	126	144	162	170	200	232
Power at	$\Delta P=35\ MPa$	P_{max}	Nm/MPa	65	73.5	84	95	100	117	152
	$\Delta P=40\ MPa$	P_{max}	Nm	75	84	96	108	114	133	174
Torque at	$\Delta P=35\ MPa$	T	Nm	312	350	445	501	594	696	1003
	$\Delta P=40\ MPa$	T	Nm	356	400	511	572	678	795	1145
Filling capacity		L	0.45	0.45	0.55	0.55	0.8	0.8	1.1	1.1
Mass(approx.)	m	kg	18	18	23	23	32	32	45	45

1) the values shown are valid for an absolute pressure (P_{abs}) of 0.1 MPa at the suction inlet S and when operated on mineral oil (with a specific mass of 0.88kg/L).

2) by increase of the input pressure ($P_{abs} > 0.1\ MPa$) the rotational speeds can be increased to the max. admissible speeds $n_{max\ limit}$ (speed limits) (see diagram page 99).

● Determining the size

$$\text{Flow} \quad q_v = \frac{V_g \cdot n \cdot \eta_v}{1000} \quad [\text{L/min}]$$

V_g = Displacement per revolution in mL/r

ΔP = Differential pressure in MPa

$$\text{Torque} \quad T = \frac{V_g \cdot \Delta P}{20 \pi \cdot \eta_{mh}} \quad [\text{Nm}]$$

n = Speed in rpm

η_v = Volumetric efficiency

η_{mh} = Mechanical-hydraulic efficiency

$$\text{Power} \quad P = \frac{2 \pi \cdot T \cdot n}{60000} = \frac{q_v \cdot \Delta P}{600 \cdot \eta_t} \quad [\text{kW}]$$

η_t = Overall efficiency

Technical Data

Hydraulic fluid

The A2FO fixed displacement pump is suitable for use with mineral oil.

Viscosity range

We recommend that a viscosity (at operating temperature) for optimum efficiency and service life purposes of

$$V_{\text{opt}} = \text{optimum viscosity } 16 \dots 36 \text{ mm}^2/\text{s}$$

Be chosen, taken the tank temperature (open circuit) into account.

Limits of viscosity range

The following values apply in extreme cases:

$V_{\text{min}} = 5 \text{ mm}^2/\text{s}$
 short term ($t < 3 \text{ min}$) at max. permitted temperature
 $t_{\text{max}} = 115^\circ\text{C}$

$V_{\text{max}} = 1600 \text{ mm}^2/\text{s}$
 short term ($t < 3 \text{ min}$) with cold start ($P < 3 \text{ MPa}$,
 $n \leq 1000 \text{ rpm}$, $t_{\text{min}} = -40^\circ\text{C}$)

Note that the maximum hydraulic fluid temperature must not be exceeded locally either (e.g. bearing area). The temperature in the bearing area is depending on pressure and speed - up to 12 K higher than the average case drain temperature.

Selection diagram

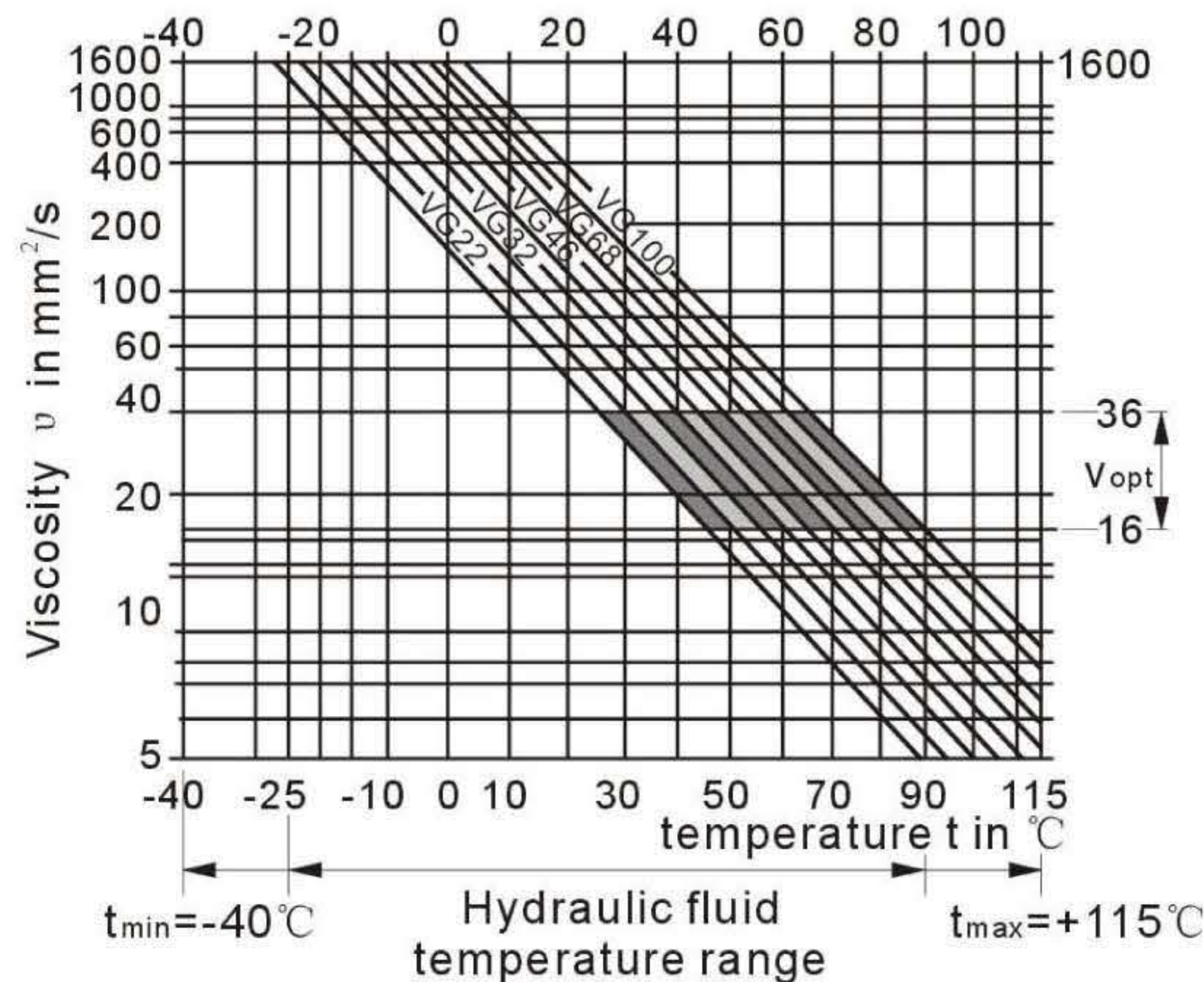

Details regarding the choice of hydraulic fluid

The correct selection of hydraulic fluid requires knowledge of the operating temperature in relation to the ambient temperature, in an open circuit the tank temperature.

The hydraulic fluid should be selected so that within the operating temperature range, the operating viscosity lies within the optimum range (v_{opt}) (see shaded section of the selection diagram). We recommend that the highest possible viscosity range should be chosen in each case.

Example: At an ambient temperature of $X^\circ\text{C}$ an operating temperature of 60°C is set in the circuit. In the optimum operating viscosity range (v_{opt} ; shaded area) this corresponds to the viscosity classes VG 46 or VG 68; to be selected: VG 68.

Please note: The leakage fluid temperature, which is affected by pressure and rotational speed, is always higher than the tank temperature. At no point in the system may the temperature be higher than 115°C .

Filtration

The finer the filtration, the cleaner the fluid and the longer the service life of the axial piston unit.

To ensure proper function of the axial piston unit, the hydraulic fluid must have a cleanliness level of at least

20/18/15 according to ISO 4406.

At very high hydraulic fluid temperatures (90°C to max. 115°C), a cleanliness level of at least

19/17/14 according to ISO 4406 is required.

Operational pressure range

Inlet

Pressure at port S

The minimum inlet pressure depends on speed. The following limits must not be exceeded.

$P_{\text{abs min}}$ _____ 0.08 MPa

$P_{\text{abs max}}$ _____ 3 MPa

Minimum inlet pressure at suction port S with increased speed

In order to avoid damage of the pump a minimum inlet pressure at the suction port must be assured. The minimum inlet pressure is related to the rotational speed of the fixed pump.

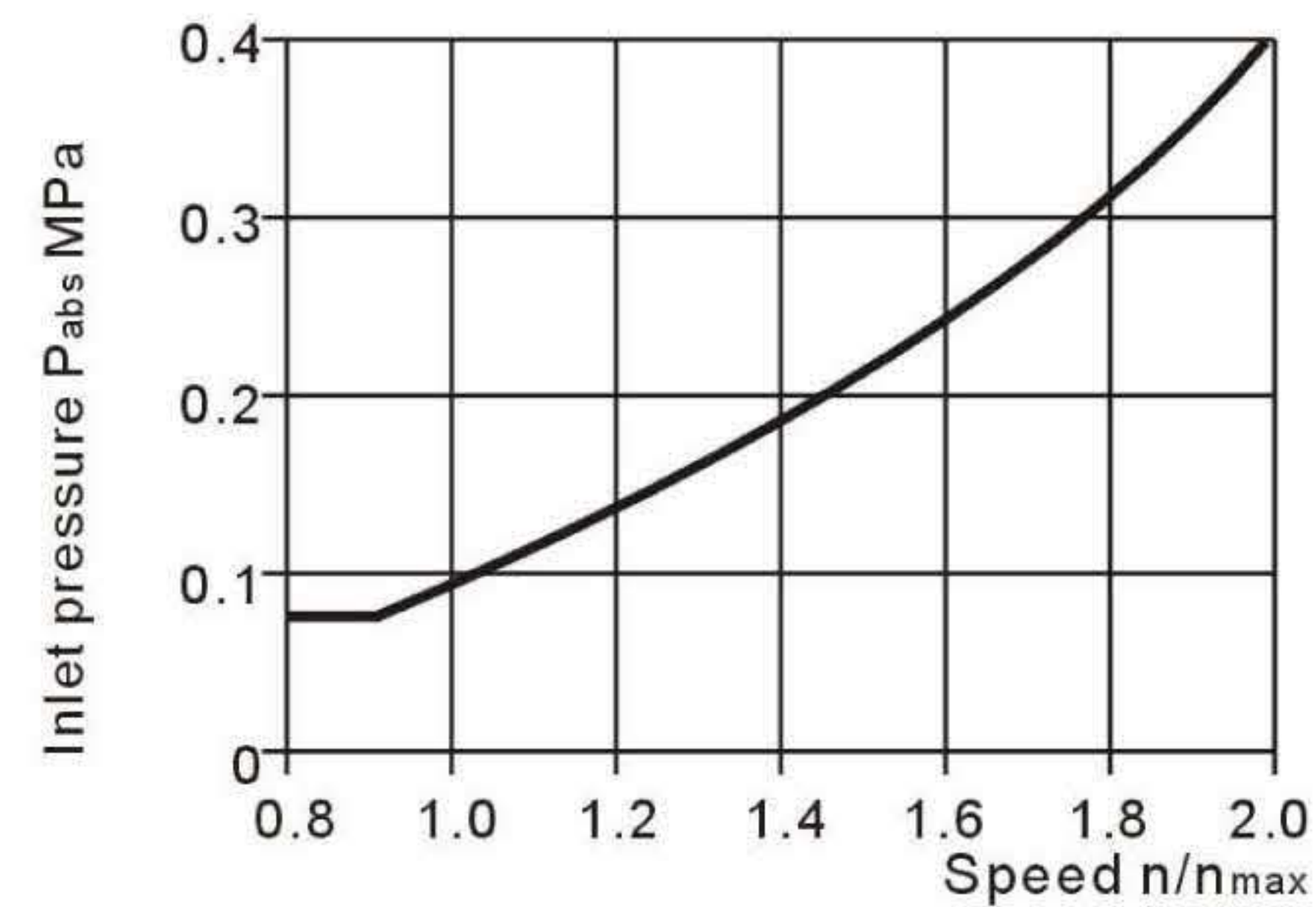

Note:

- max. permissible speed $n_{\text{max perm.}}$ (speed limit)
- min. permissible inlet pressure at port S
- admissible values for the drive shaft seal

Outlet

Maximum pressure on port A or B (pressure data according to DIN 24312)

	Shaft end A, Z	Shaft end B, P
Nominal pressure P_N	40 MPa	35 MPa
Peak pressure P_{max}	45 MPa	40 MPa

Direction of flow

Direction of rotation, viewed on shaft end

clockwise _____ counter-clockwise

S to B _____ S to A

Symbol

Connections

A, B Service line port
 S Suction port
 T_1, T_2 Drain ports

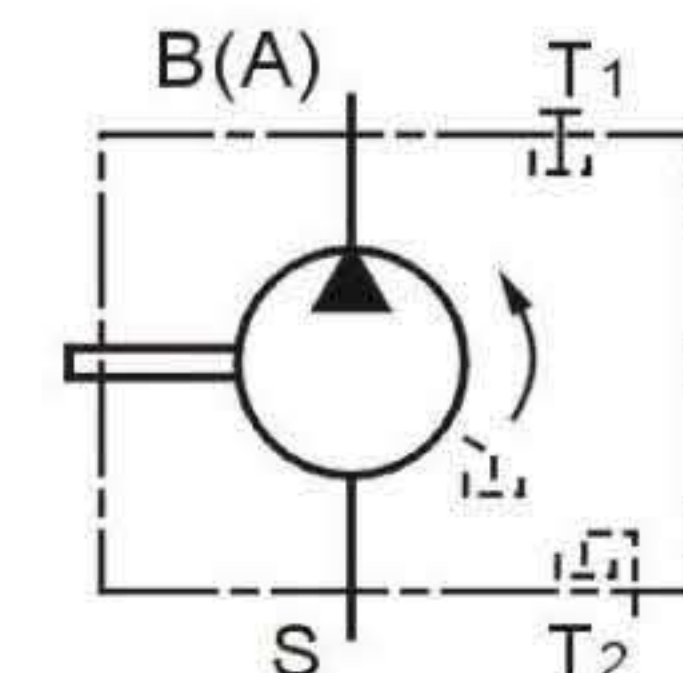

Model Code

A2F	O	80	/6	1	R	-P	A	B	05
Axial piston unit	Mode of operation	Size (mL/r)	Series	Index	Direction of rotation	Seals	Shaft end	Mounting flange	Service line ports
A2F: Bent axis design, fixed displacement	O: Pump, open circuits	10	6	1	(Viewed on shaft end) R: Clockwise L: Counter-clockwise	P: NBR (nitril~caoutchouc) V: FKM (fluor~caoutchouc)	See below	B: 4-hole ISO 3019-2	See below
		12							
		16							
		23							
		28							
		32							
		45							
		56							
		63							
		80							
		90							
		107							
		125							
160									
180									

Shaft end

Size		10	12	16	23	28	32	45	56	63	80	90	107	125	160	180
Spined shaft DIN 5480	A	✓	✓	✓	✓	✓	✓	/	✓	✓	✓	✓	✓	✓	✓	✓
	Z	✓	✓	/	✓	✓	/	✓	✓	/	✓	/	✓	/	✓	/
Parallel keyed shaft, DIN 6885	B	✓	✓	✓	✓	✓	✓	/	✓	✓	✓	✓	✓	✓	✓	✓
	P	✓	✓	/	✓	✓	/	✓	✓	/	✓	/	✓	/	✓	/

Service line port¹⁾

Size	10	12	16	23	28	32	45	56	63	80	90	107	125	160	180
05:SAE flange ports A and B, at side and SAE flange port S, rear	/	/	/	✓	✓	✓	✓	✓	✓	✓	✓	✓	✓	✓	✓
06:Threaded ports A and B, at side and SAE flange port S, rear	✓	✓	✓	/	/	/	/	/	/	/	/	/	/	/	/

✓ = available / = not available

1) fastening threads resp. threaded ports are metric